

Approval body for construction products
and types of construction

Bautechnisches Prüfamt

An institution established by the Federal and
Laender Governments



European Technical Assessment

ETA-07/0013
of 17 March 2017

English translation prepared by DIBt - Original version in German language

General Part

Technical Assessment Body issuing the
European Technical Assessment:

Deutsches Institut für Bautechnik

Trade name of the construction product

EJOT Flat Roof Fasteners

Product family
to which the construction product belongs

Fasteners for flexible roof waterproofing membrane
systems

Manufacturer

EJOT Baubefestigungen GmbH
In der Stockwiese 35
57334 Bad Laasphe
DEUTSCHLAND

Manufacturing plant

Werk 1 bis 13
Factory 1 to 13

This European Technical Assessment
contains

68 pages including 63 annexes which form an integral
part of this assessment

This European Technical Assessment is
issued in accordance with Regulation (EU)
No 305/2011, on the basis of

Guideline for European technical approval of
"Mechanically fastened flexible roof waterproofing
membranes", ETAG 006,
used as European Assessment Document (EAD)
according to Article 66 Paragraph 3 of Regulation (EU)
No 305/2011.

The European Technical Assessment is issued by the Technical Assessment Body in its official language. Translations of this European Technical Assessment in other languages shall fully correspond to the original issued document and shall be identified as such.

Communication of this European Technical Assessment, including transmission by electronic means, shall be in full. However, partial reproduction may only be made with the written consent of the issuing Technical Assessment Body. Any partial reproduction shall be identified as such.

This European Technical Assessment may be withdrawn by the issuing Technical Assessment Body, in particular pursuant to information by the Commission in accordance with Article 25(3) of Regulation (EU) No 305/2011.

Specific part

1 Technical description of the product

The products are mechanical fasteners. The fasteners comprise a screw made of coated carbon steel or stainless steel and either a washer with or without integrated sleeve or a bar. The washers without integrated sleeve are made of coated carbon steel whereas the washers with integrated sleeve are made of plastic materials (polyamide or polyethylene). The bars are made of coated carbon steel.

The fasteners are shown in the Annexes to this ETA.

2 Specification of the intended use in accordance with the applicable European Assessment Document

The fasteners are intended to be used for the fastening of flexible roof waterproofing membranes according to ETAG 006. The possible substrates are steel decks, concrete, aerated concrete, light concrete, timber or wood-based material, sheets of steel and aluminium as well as sandwich panels.

The performances given in Section 3.2 are only valid if the fasteners are used in compliance with the specifications and conditions given in sections 3.1 and 3.3 and the Annexes to this ETA.

The verifications and assessment methods on which this European Technical Assessment is based lead to the assumption of a working life of the fasteners of at least 10 years. The indications given on the working life cannot be interpreted as a guarantee given by the producer, but are to be regarded only as a means for choosing the right products in relation to the expected economically reasonable working life of the works.

In order to use the fasteners for systems of mechanically fastened flexible roof waterproofing membranes according to ETAG 006 a separate ETA is necessary for the entire roof waterproofing system. The system ETA covers the wind uplift resistance of the entire system as well as the product characteristics of the components of the system.

3 Performance of the product and references to the methods used for its assessment

3.1 Characteristics of the product

The fasteners shall correspond to the information given in Annexes 1 to 60.

The material properties, dimensions and tolerances not indicated in Annexes 1 to 60 shall correspond to the information laid down in the technical information¹ to this European technical approval.

3.2 Safety and accessibility in use (BWR 4)

Essential characteristic	Performance
Characteristic tensile loading	See Annexes 61 to 63
Resistance to unwinding	pass
Resistance to corrosion of metallic fasteners	pass; ≤ 15 % surface corrosion

¹ The technical documentation is deposited with Deutsches Institut für Bautechnik and as far as relevant for the tasks of the approved bodies involved in the attestation of conformity procedure is handed over to the approved bodies.

Essential characteristic	Performance
Impact resistance and brittleness of plastic fasteners (before and after heat ageing)	pass; drop height > 1,0 m
Requirements for results of Charpy tests for plastic materials (before and after heat ageing)	pass; not any decline compared to the results before heat ageing

The thickness and strengths of the materials listed in the tables of characteristic tensile loads (Annexes 61 to 63) are minimum requirements. The values given are also applicable for materials with higher thickness and strengths. The values of axial loading shown in Annexes 61 to 63 were determined by axial loading tests according to ETAG 006.

The fasteners are deemed to satisfy the requirements of ETAG 006 concerning unwinding. This was evaluated on the basis of the existing field experience of the manufacturer.

The durability requirements of ETAG 006 (resistance to corrosion of metallic fasteners, impact resistance and brittleness of plastic fasteners before and after heat ageing, requirements for results of Charpy tests for plastic materials before and after heat ageing) are satisfied for the coated carbon steel, stainless steel, polyamide and polyethylene components of the fasteners.

All coated carbon steel components resisted to 15 cycles of the test procedure described in ETAG 006 (Kesternich test) and did not show more than 15 % surface corrosion.

The test results of the tests to check the impact resistance and brittleness of the polyamide and polyethylene components showed a drop height of more than 1.0 m before and after heat ageing of these components. Furthermore the results of the corresponding Charpy tests after heat ageing did not show any decline compared to the results before heat ageing.

3.3 Indications concerning installation

The installation is solely carried out according to the manufacturer's instructions. The manufacturer hands over the assembly instructions to the assembler. The conformity of the installed fastener with this ETA is attested by the executing company.

It is in the responsibility of the manufacturer to ensure that the information on the specific conditions according to 1, 2, 3.1 and 3.2 is given to those who are concerned. The information may be given by reproduction of the ETA. In addition all installation data shall be shown clearly on the package and/or on an enclosed instruction sheet, preferably using illustration(s).

4 Assessment and verification of constancy of performance (AVCP) system applied, with reference to its legal base

In accordance with ETAG 006 the applicable European legal act is: 1998/143/EC.

The system to be applied is: 2+

5 Technical details necessary for the implementation of the AVCP system, as provided for in the applicable EAD

Technical details necessary for the implementation of the AVCP system are laid down in the control plan deposited with Deutsches Institut für Bautechnik.

Issued in Berlin on 17 March 2017 by Deutsches Institut für Bautechnik

Uwe Bender
Head of Department

beglaubigt:
Schult



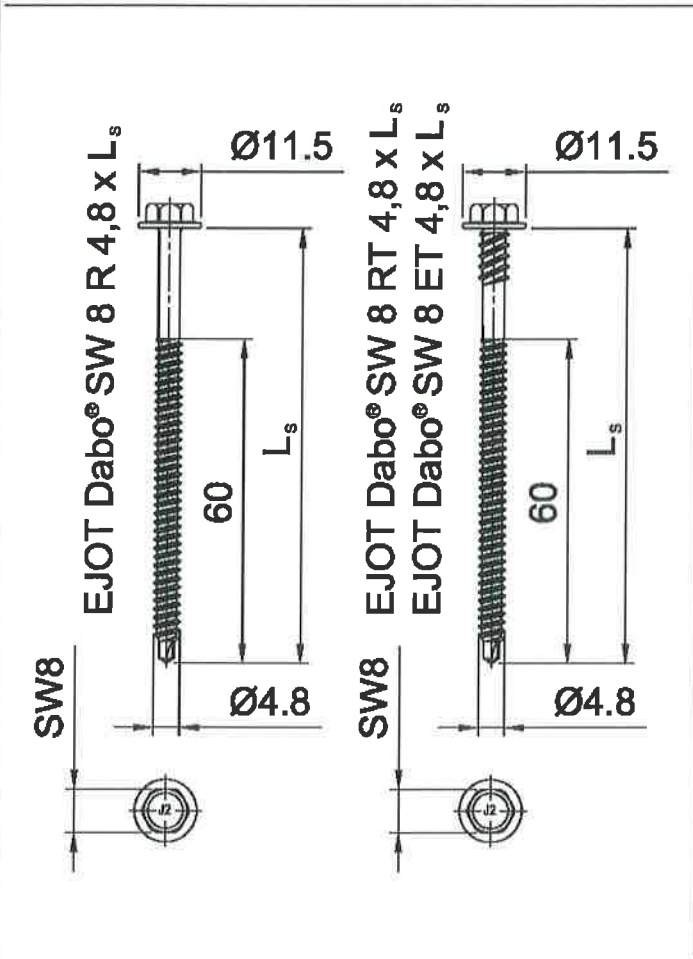
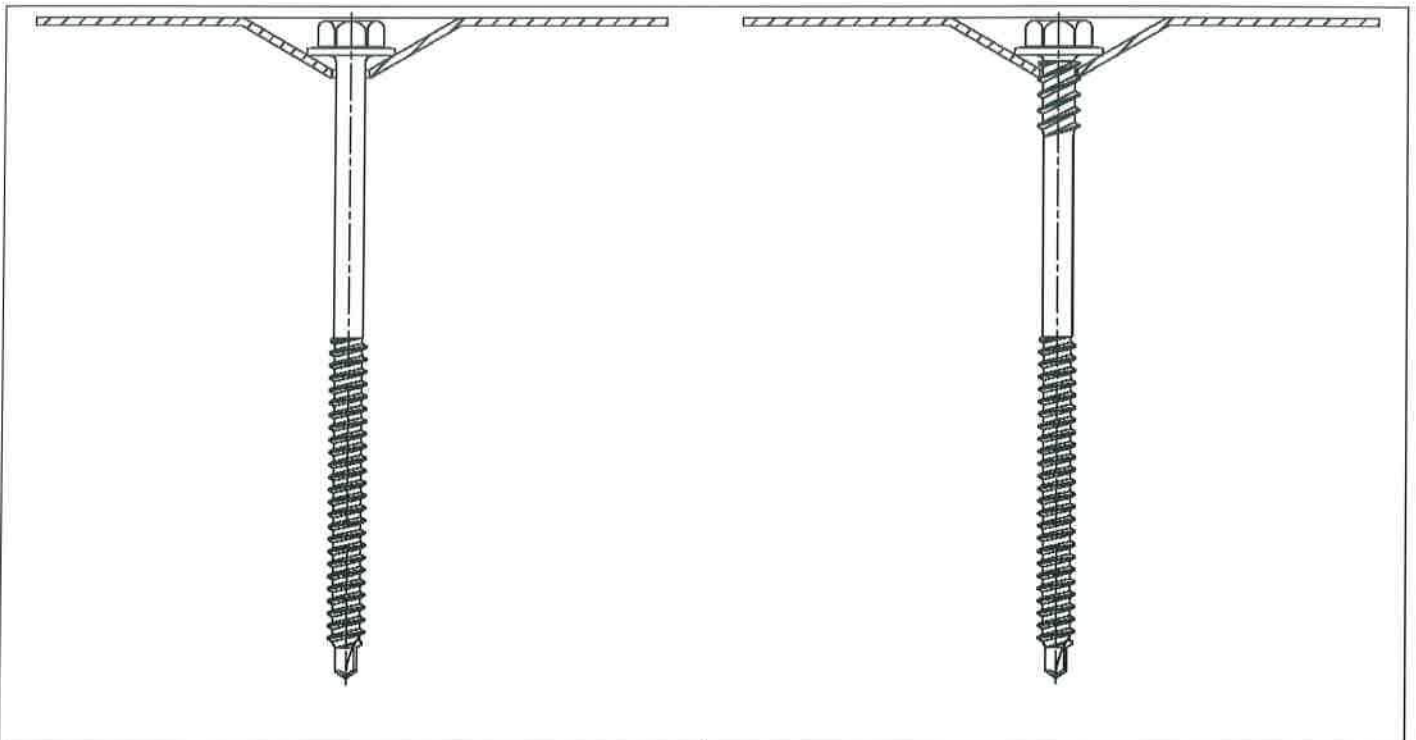

EJOT® HTV 82/40
EJOT® HTE 82/40

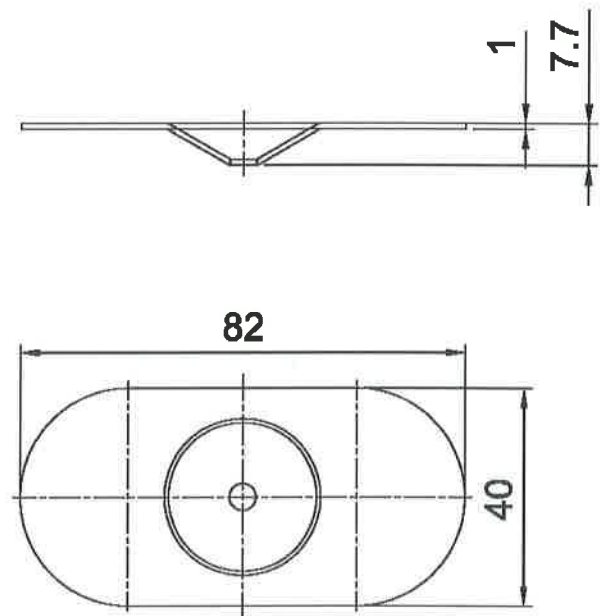

EJOT Flat Roof Fasteners

Combination 1-6:
Fastener: EJOT DABO® SW 8 R x L_s / DABO® SW 8 RT x L_s / DABO® SW 8 ET x L_s
Washer: EJOT® HTV 82/40 / EJOT® HTE 82/40

Annex 1

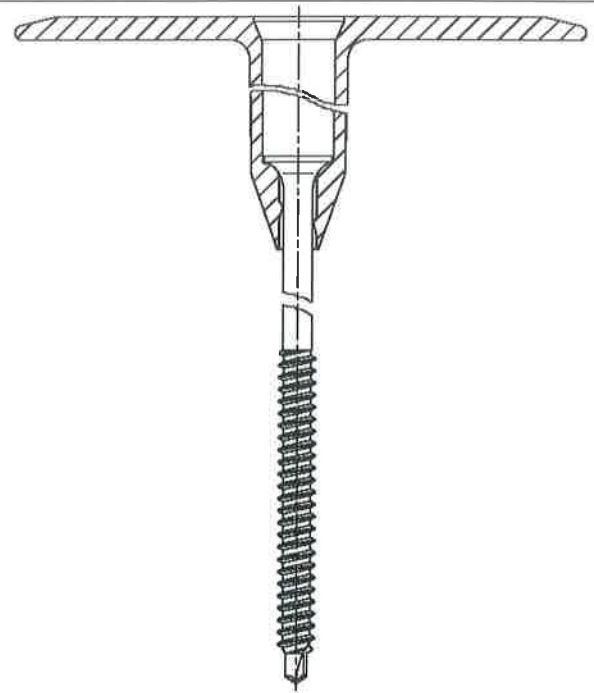
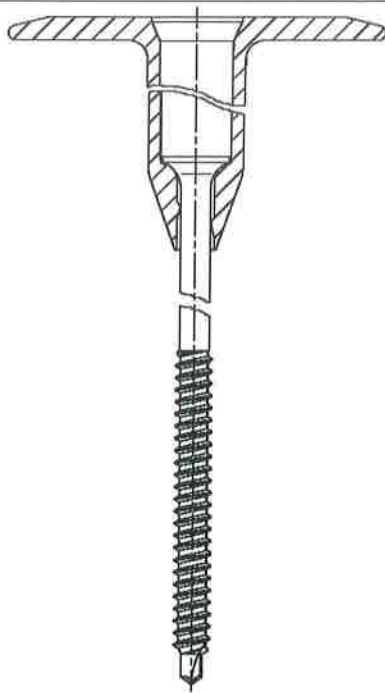

EJOT Dabo® TKR - 4,8 x L_s
EJOT Dabo® TKE - 4,8 x L_s

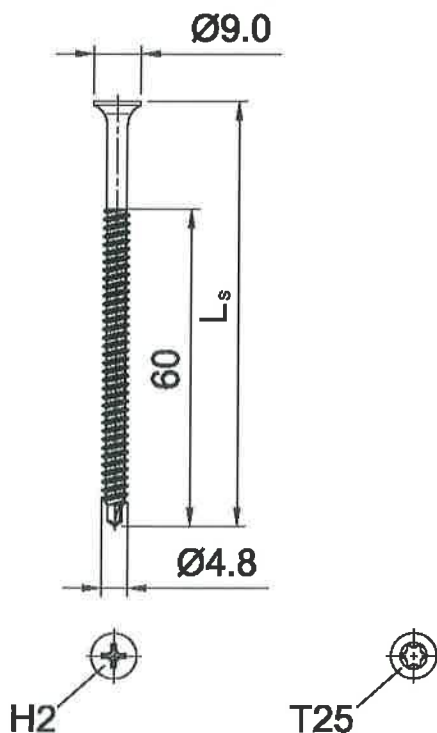

EJOT® HTK 2G - 50 x L_B
Ø50

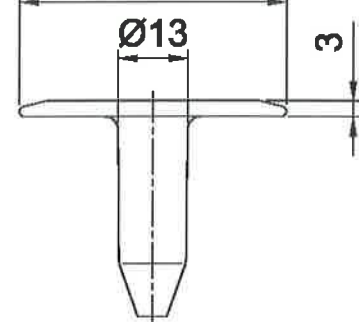

EJOT® HTK 2G - 75 x L_B
Ø75



EJOT Flat Roof Fasteners

Combination 7-10:
Fastener: EJOT DABO® TKR - 4,8 x L_s / EJOT DABO® TKE - 4,8 x L_s
Washer: EJOT® HTK 2G - 50 x L_B / EJOT® HTK 2G - 75 x L_B

Annex 2

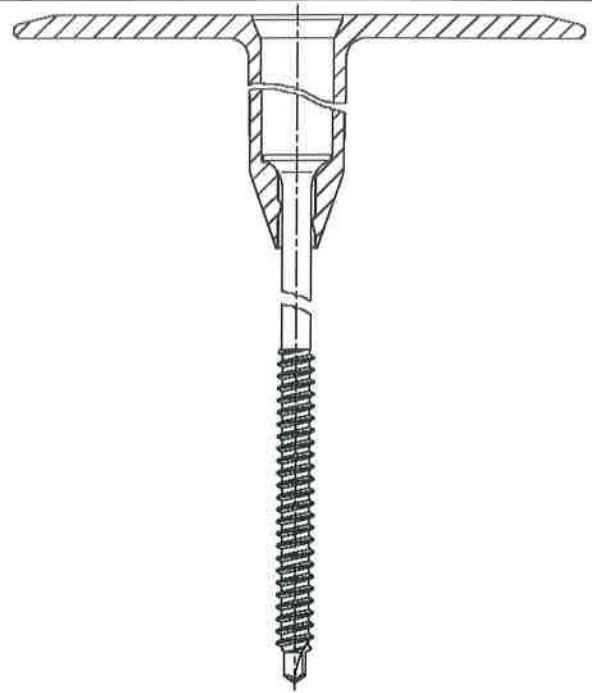
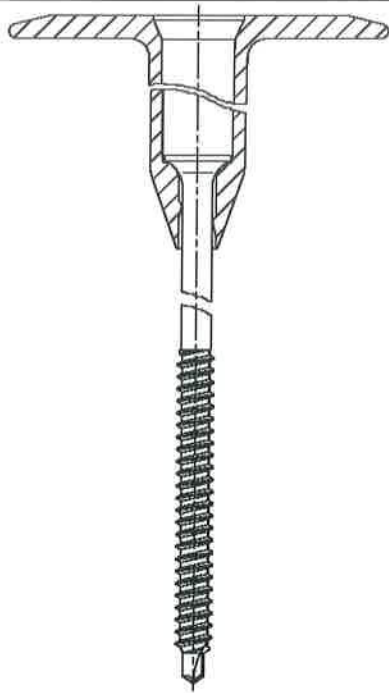

EJOT Dabo® TKR - 4 - 4,8 x L_s

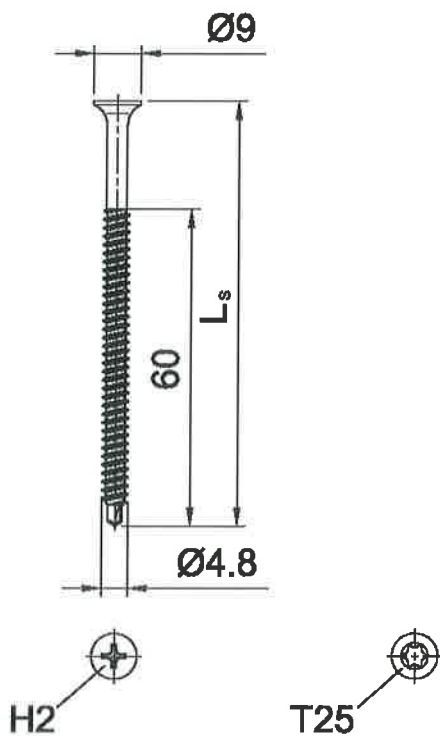

EJOT® HTK 2G - 50 x L_B

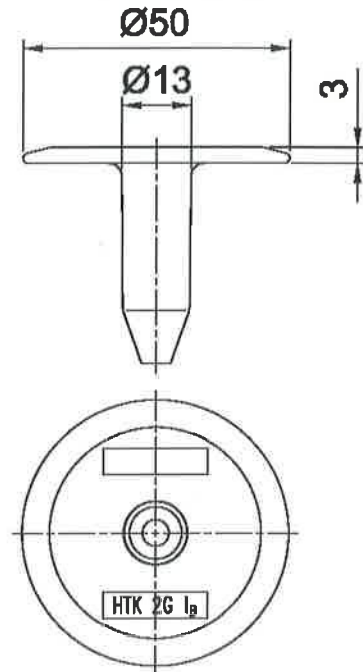

EJOT® HTK 2G - 75 x L_B



EJOT Flat Roof Fasteners

Combination 11-12:

Fastener: EJOT DABO® TKR - 4 - 4,8 x L_s

Washer: EJOT® HTK 2G - 50 x L_B / EJOT® HTK 2G - 75 x L_B

Annex 3

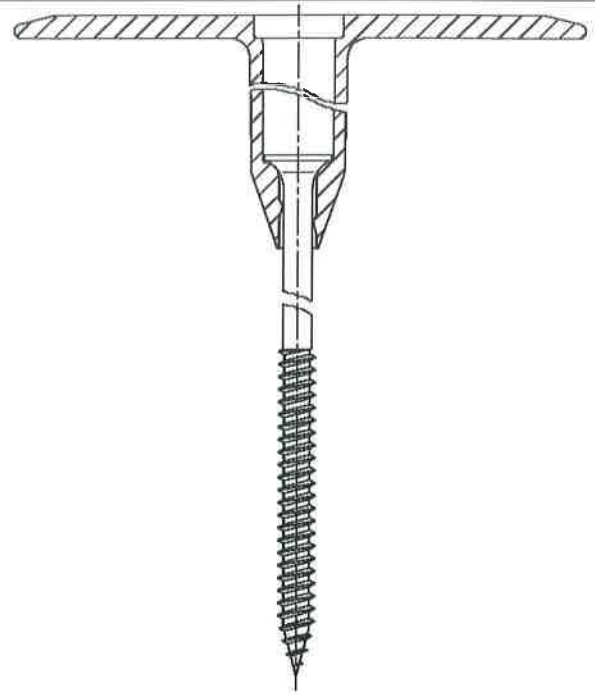
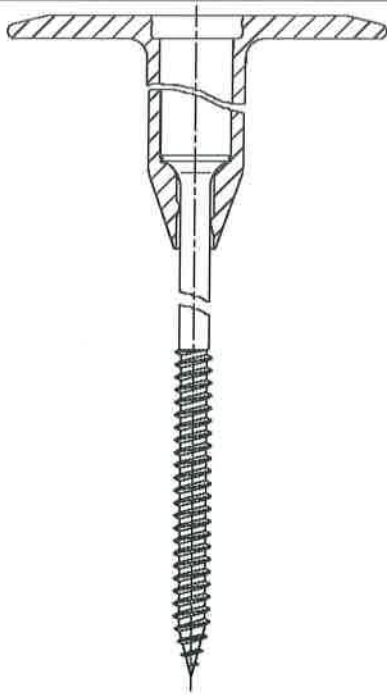

EJOT Dabo® VHT - R - 4,8 x L_s
EJOT Dabo® VHT - E - 4,8 x L_s

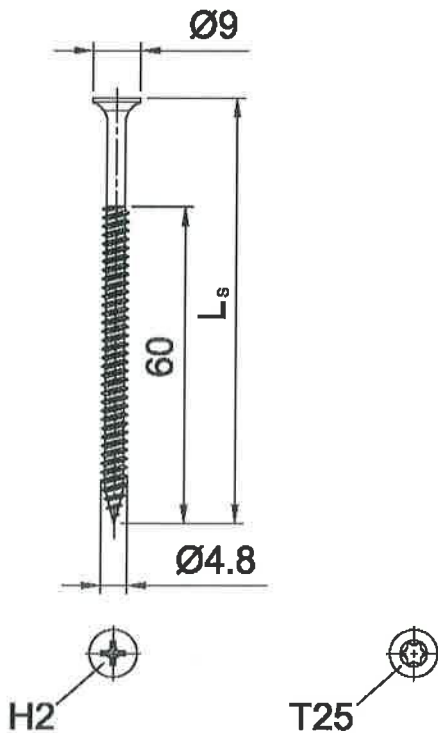

EJOT® HTK 2G - 50 x L_B

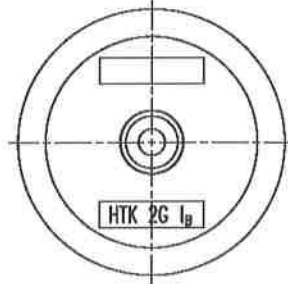
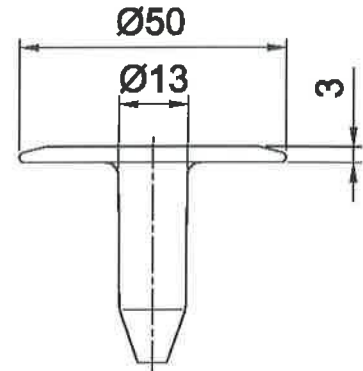

EJOT® HTK 2G - 75 x L_B

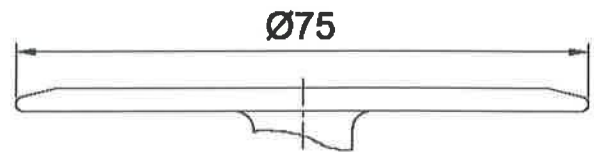

EJOT Flat Roof Fasteners

Combination 13-16:

Fastener: EJOT DABO® VHT - R - 4,8 x L_s / EJOT DABO® VHT - E - 4,8 x L_s

Washer: EJOT® HTK 2G - 50 x L_B / EJOT® HTK 2G - 75 x L_B

Annex 4

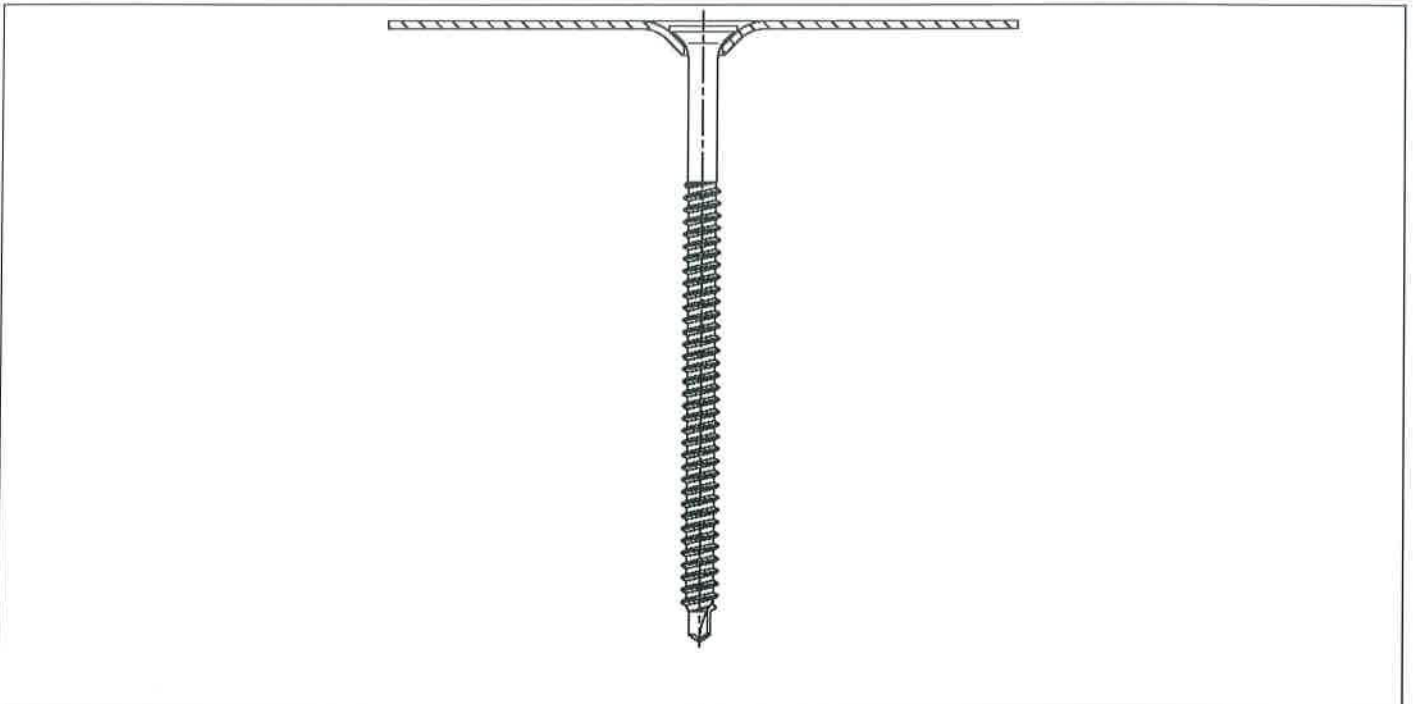

EJOT Dabo® TKR - 4,8 x L_s
EJOT Dabo® TKE - 4,8 x L_s

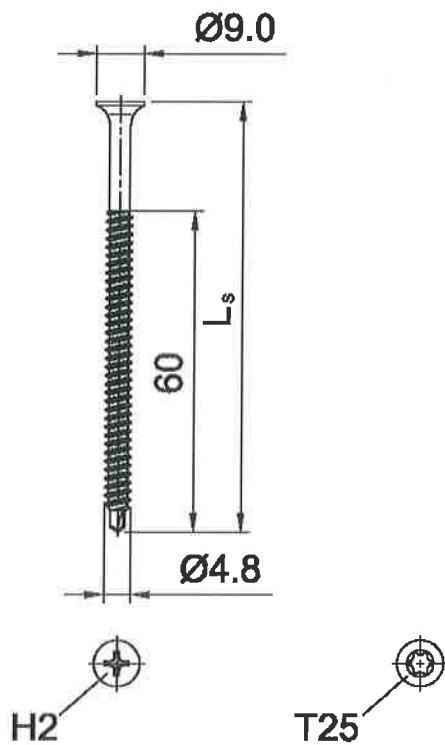

EJOT® HTV 82/40 TK

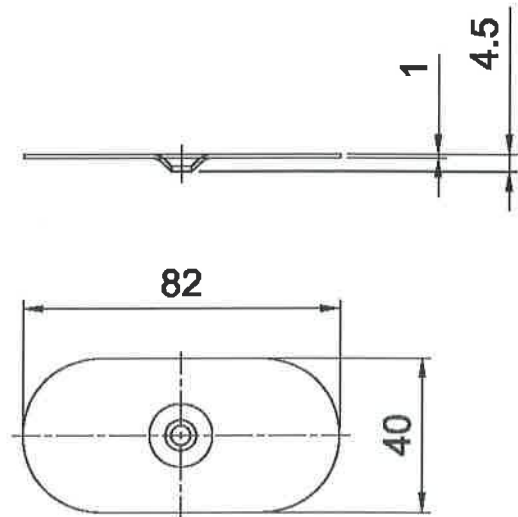

EJOT Flat Roof Fasteners

Combination 17-18:
Fastener: EJOT DABO® TKR - 4,8 x L_s / EJOT DABO® TKE - 4,8 x L_s
Washer: EJOT® HTV 82/40 TK

Annex 5

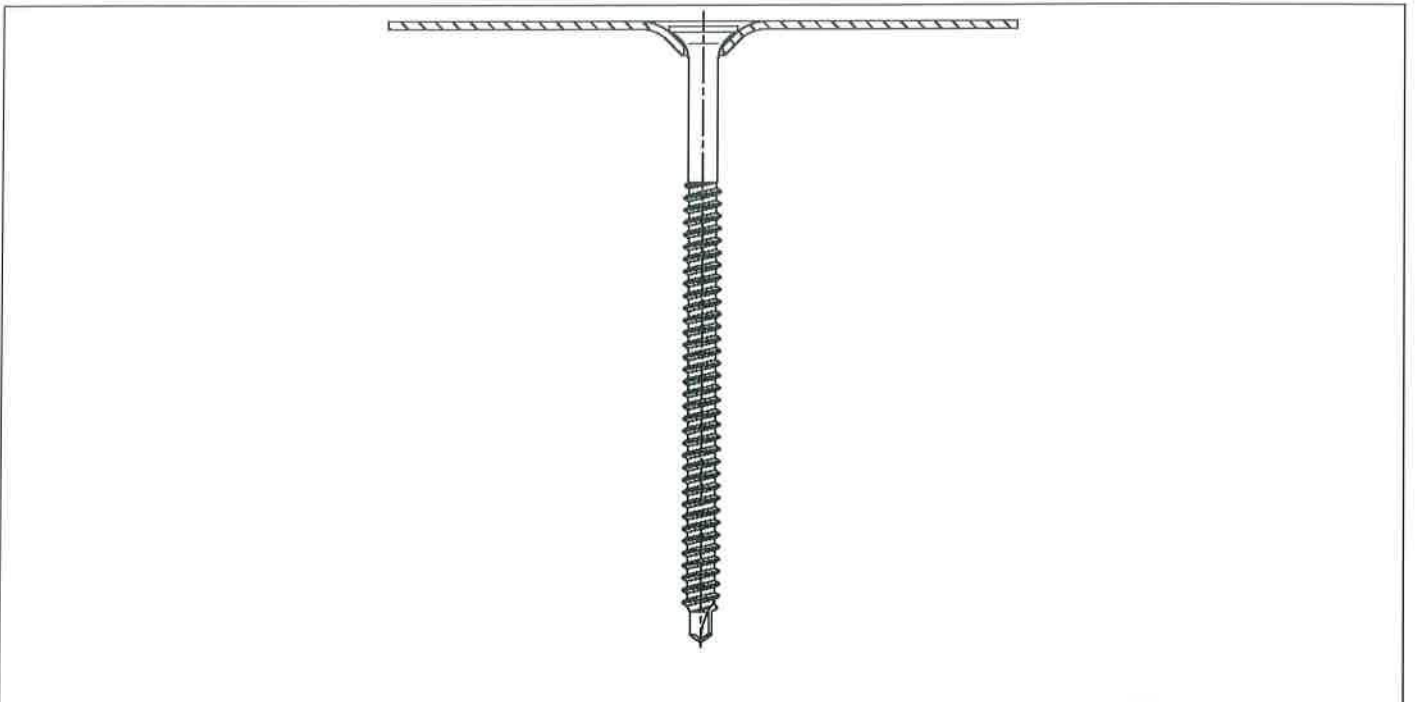

EJOT Dabo® TKR - 4 - 4,8 x L_s

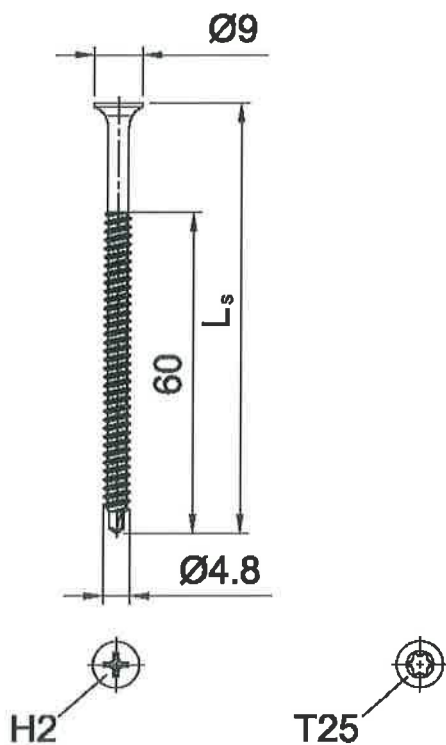

EJOT® HTV 82/40 TK

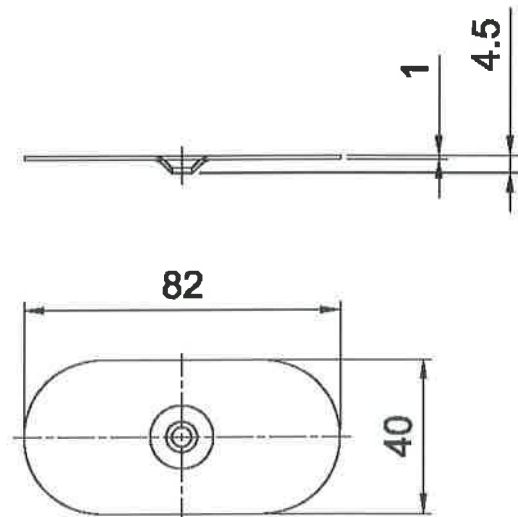

EJOT Flat Roof Fasteners

Combination 19:
Fastener: EJOT DABO® TKR - 4 - 4,8 x L_s
Washer: EJOT® HTV 82/40 TK

Annex 6

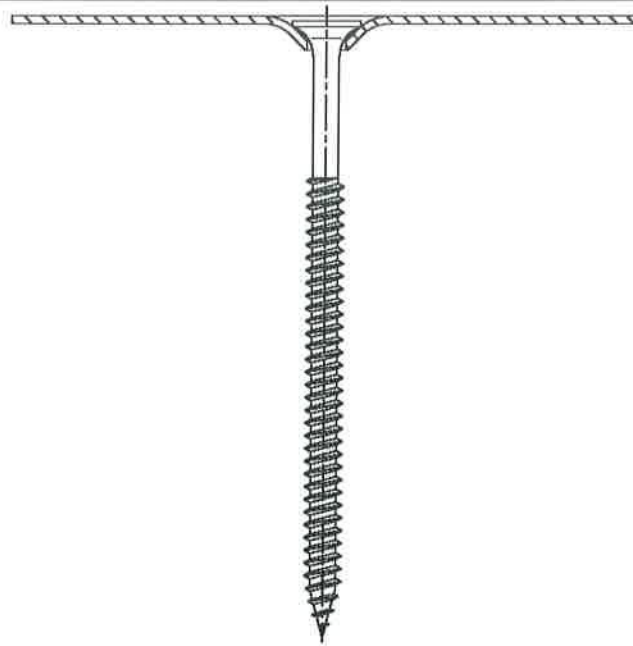

EJOT Dabo® VHT - R - 4,8 x L_s
EJOT Dabo® VHT - E - 4,8 x L_s

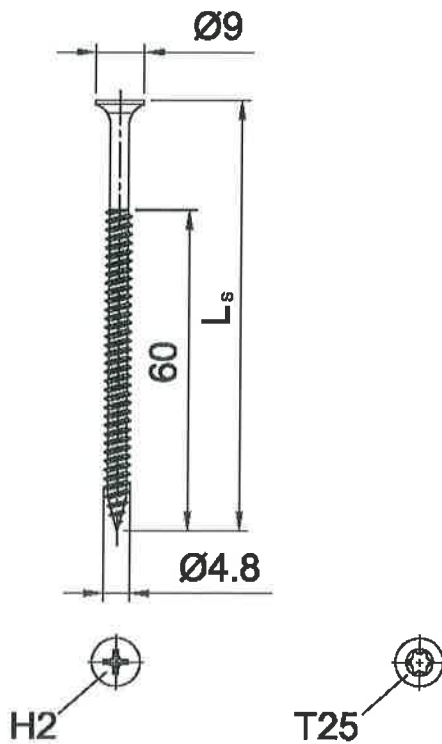

EJOT® HTV 82/40 TK

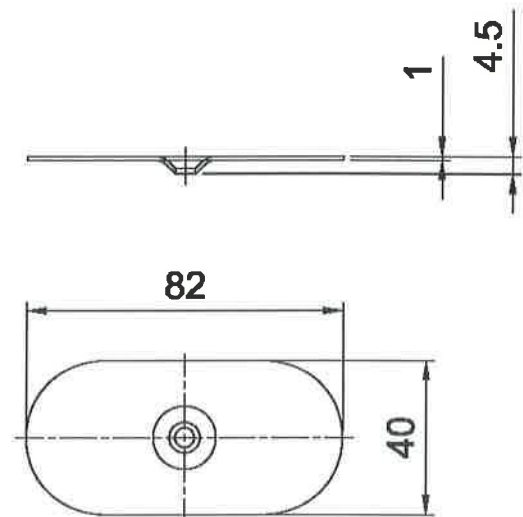

EJOT Flat Roof Fasteners

Combination 20-21:
Fastener: EJOT DABO® VHT - R - 4,8 x L_s / EJOT DABO® VHT - E - 4,8 x L_s
Washer: EJOT® HTV 82/40 TK

Annex 7

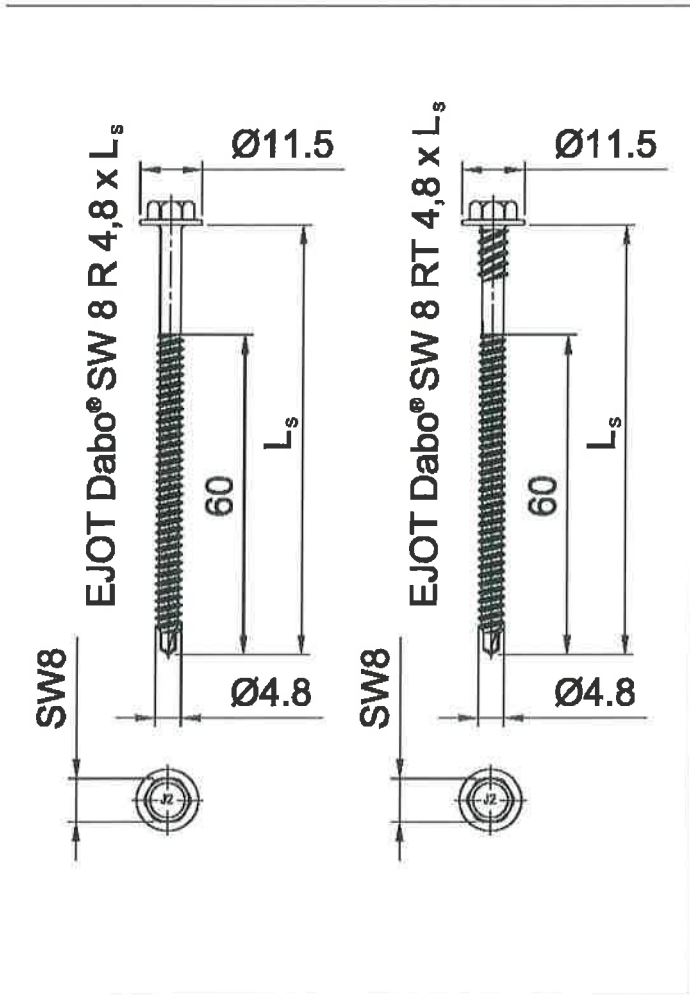
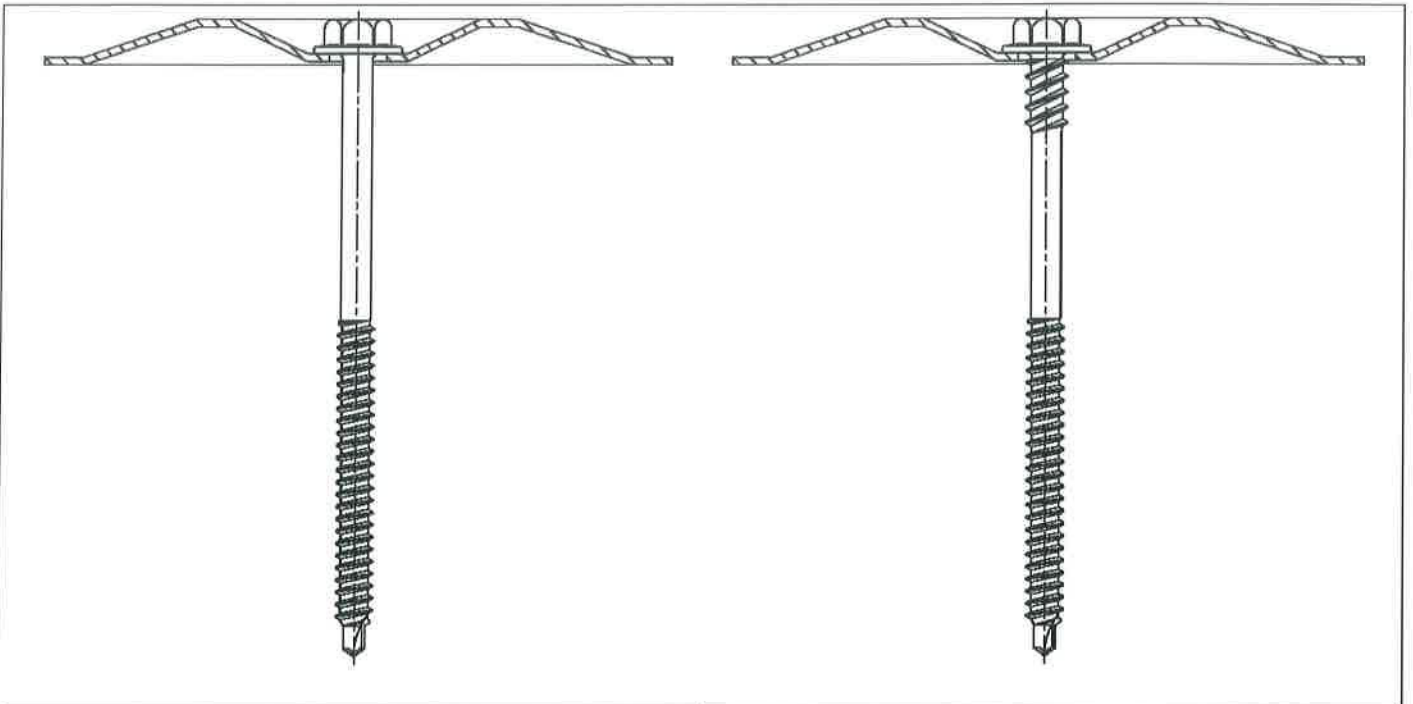

EJOT® HTV 82/40 F

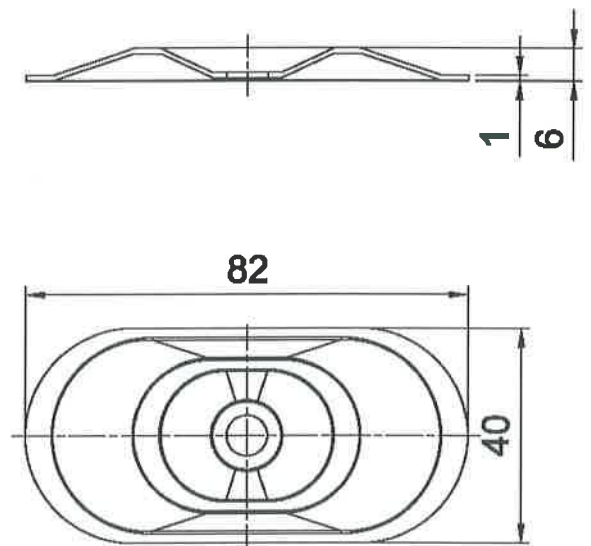

EJOT Flat Roof Fasteners

Combination 22-23:
Fastener: EJOT DABO® SW 8 R x L_s / EJOT DABO® SW 8 RT x L_s
Washer: EJOT® HTV 82/40 F

Annex 8

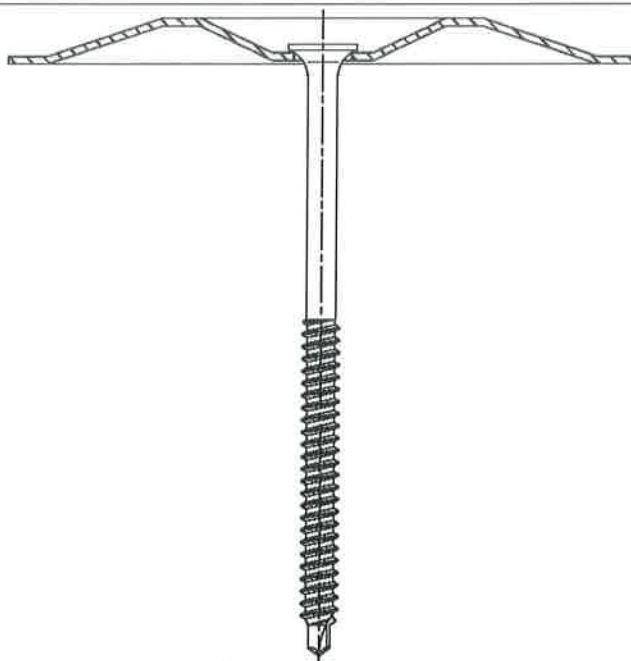

EJOT Dabo® TKR - 4,8 x L_s
EJOT Dabo® TKE - 4,8 x L_s

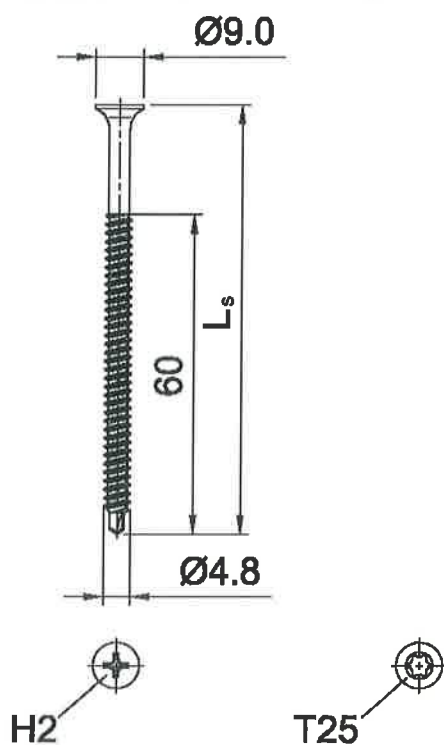

EJOT® HTV 82/40 F

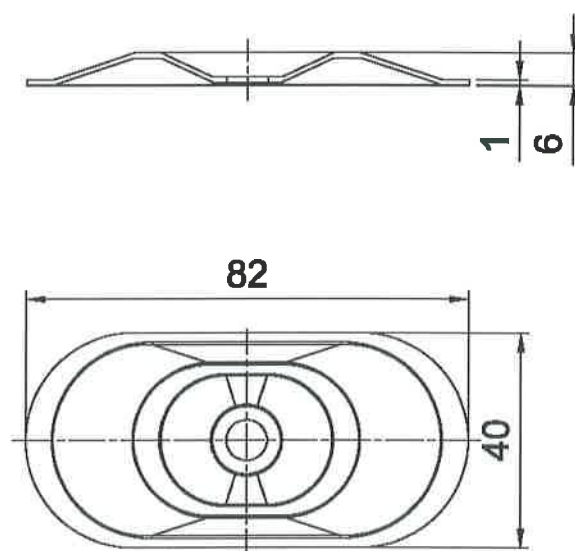

EJOT Flat Roof Fasteners

Combination 24-25:
Fastener: EJOT DABO® TKR - 4,8 x L_s / EJOT DABO® TKE - 4,8 x L_s
Washer: EJOT® HTV 82/40 F

Annex 9

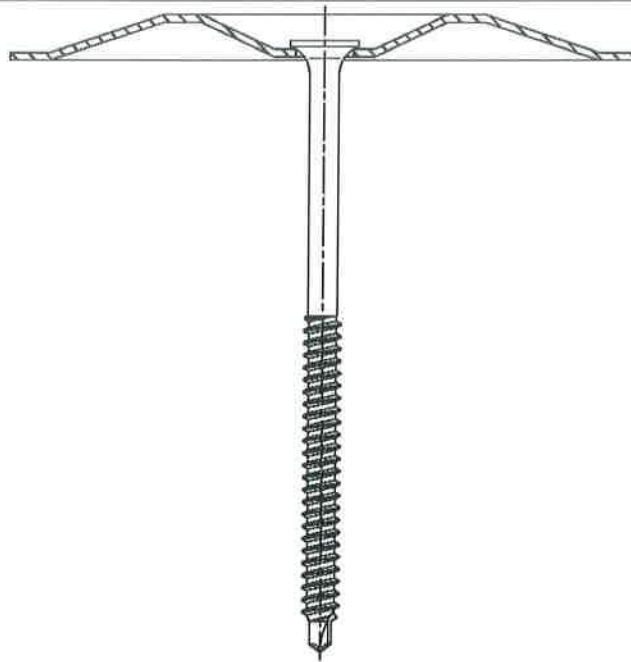

EJOT Dabo® TKR - 4 - 4,8 x L_s

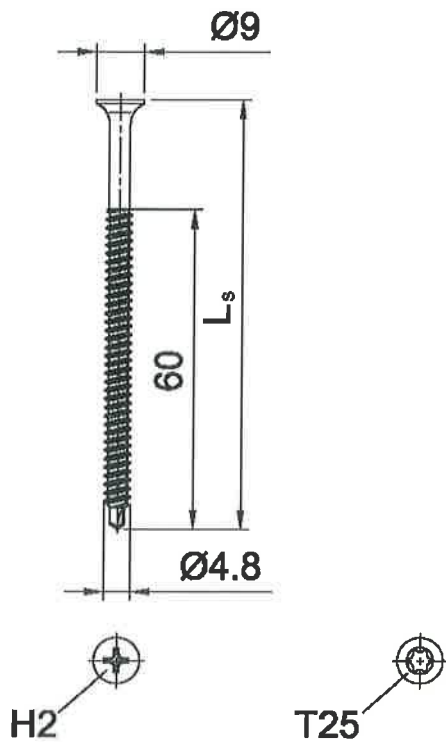

EJOT® HTV 82/40 F

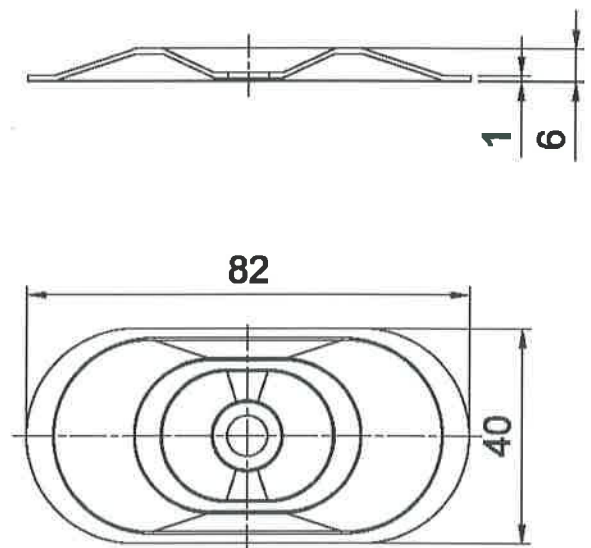

EJOT Flat Roof Fasteners

Combination 26:
 Fastener: EJOT DABO® TKR - 4 - 4,8 x L_s
 Washer: EJOT® HTV 82/40 F

Annex 10

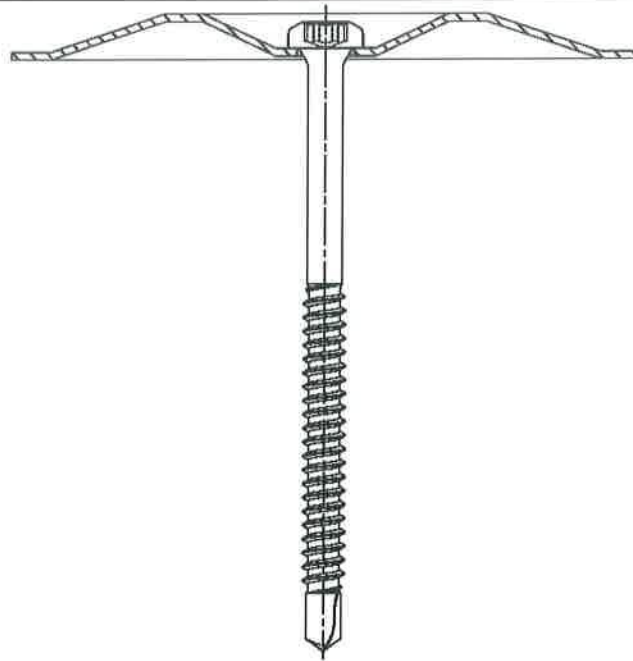

EJOT Dabo® TKR - ZT6 - 5,5 x L_s

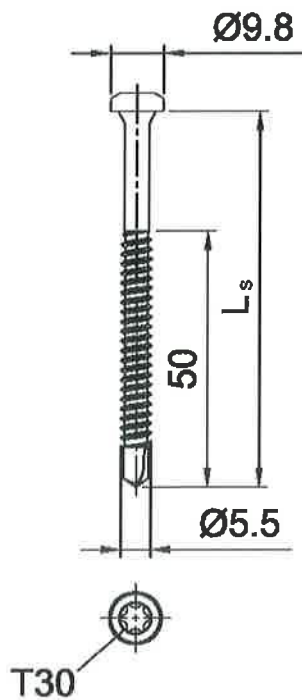

EJOT® HTV 82/40 F

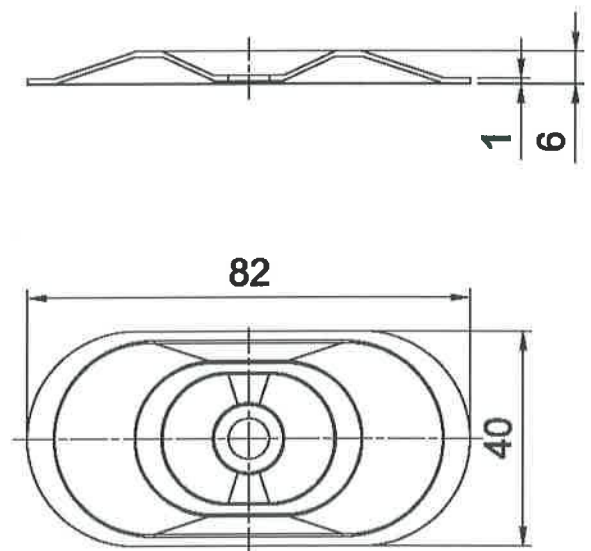

EJOT Flat Roof Fasteners

Combination 27:
Fastener: EJOT DABO® TKR – ZT6 – 5,5 x L_s
Washer: EJOT® HTV 82/40 F

Annex 11

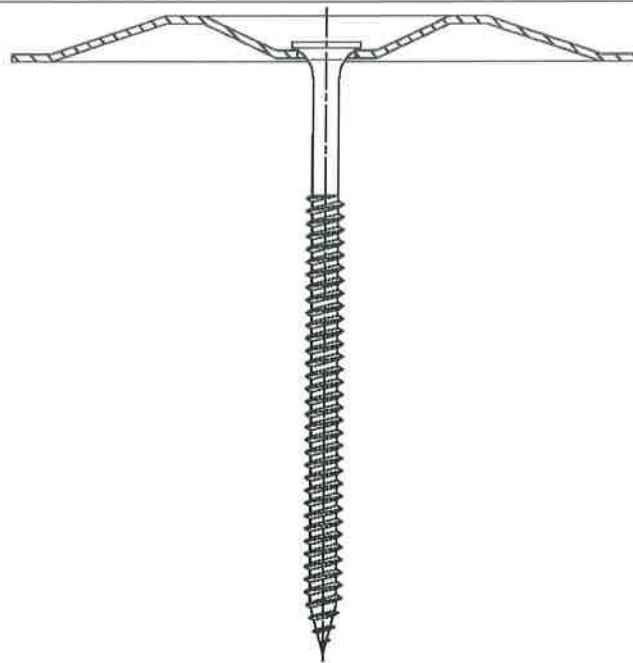

EJOT Dabo® VHT - R - 4,8 x L_s
EJOT Dabo® VHT - E - 4,8 x L_s

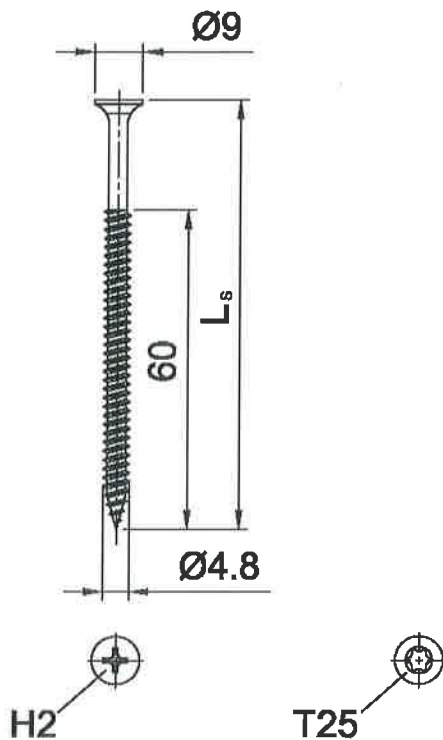

EJOT® HTV 82/40 F

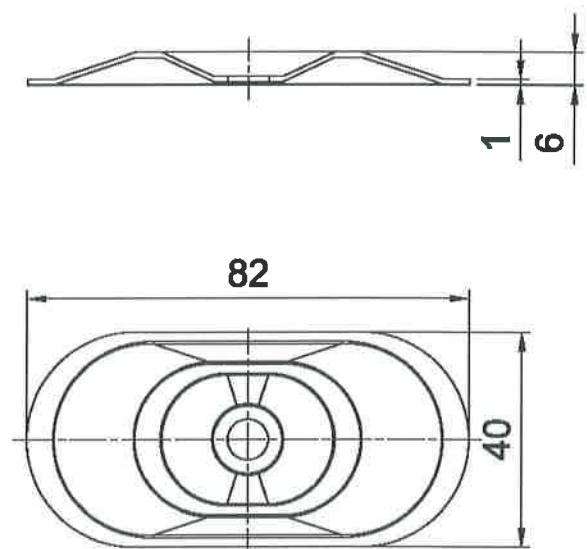

EJOT Flat Roof Fasteners

Combination 28-29:

Fastener: EJOT DABO® VHT - R - 4,8 x L_s / EJOT DABO® VHT - E - 4,8 x L_s

Washer: EJOT® HTV 82/40 F

Annex 12

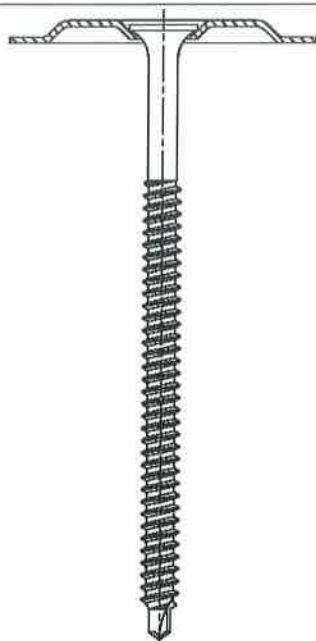

EJOT Dabo® TKR - 4,8 x L_s
EJOT Dabo® TKE - 4,8 x L_s

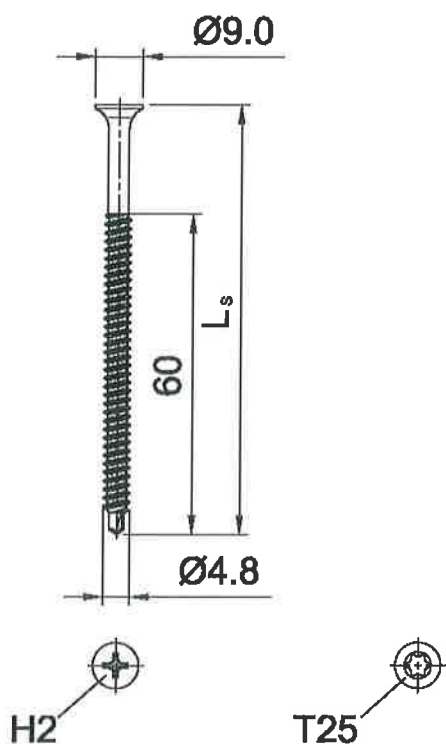

EJOT® HTV 40 RU 6,5

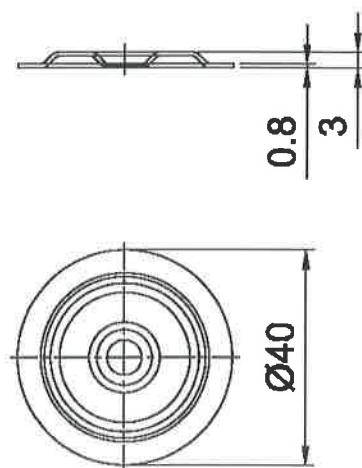

EJOT Flat Roof Fasteners

Combination 30-31:
Fastener: EJOT DABO® TKR - 4,8 x L_s / EJOT DABO® TKE - 4,8 x L_s
Washer: EJOT® HTV 40 RU

Annex 13



EJOT Dabo® TKR - 4 - 4,8 x L_s

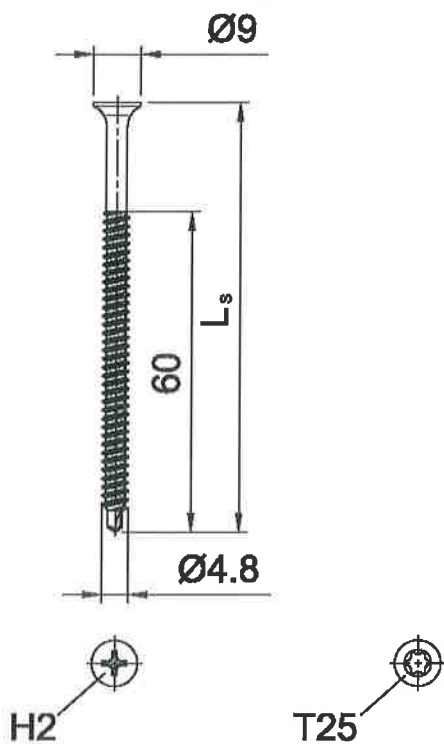

EJOT® HTV 40 RU 6,5

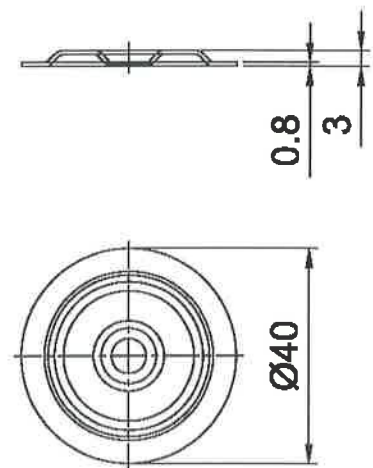

EJOT Flat Roof Fasteners

Combination 32:
Fastener: EJOT DABO® TKR - 4 - 4,8 x L_s
Washer: EJOT® HTV 40 RU

Annex 14

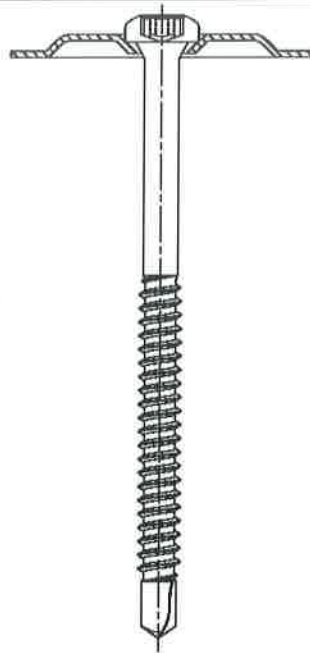

EJOT Dabo® TKR - ZT6 - 5,5 x L_s

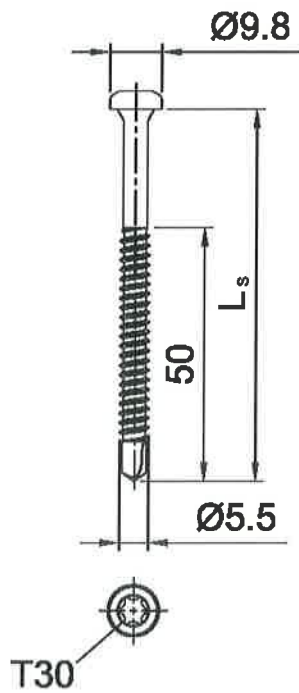

EJOT® HTV 40 RU 6,5

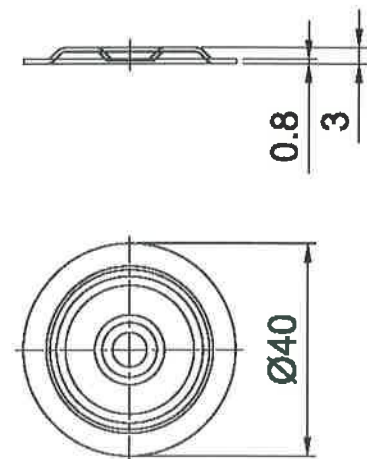

EJOT Flat Roof Fasteners

Combination 33:
Fastener: EJOT DABO® TKR – ZT6 – 5,5 x L_s
Washer: EJOT® HTV 40 RU

Annex 15

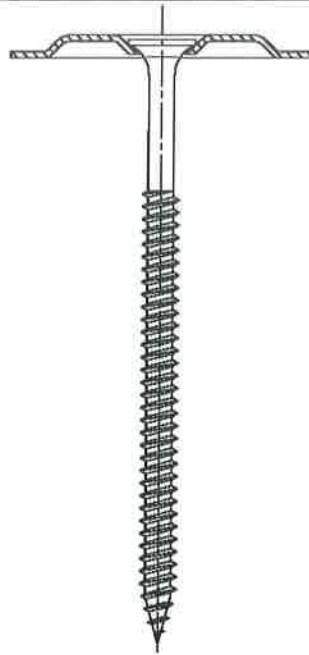

EJOT Dabo® VHT - R - 4,8 x L_s
EJOT Dabo® VHT - E - 4,8 x L_s

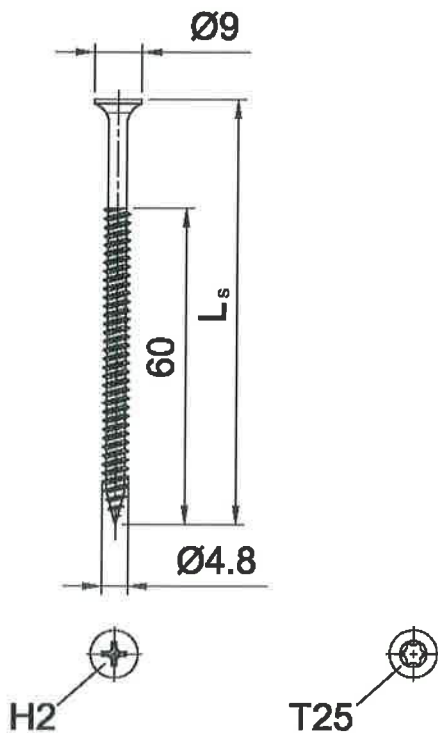

EJOT® HTV 40 RU 6,5

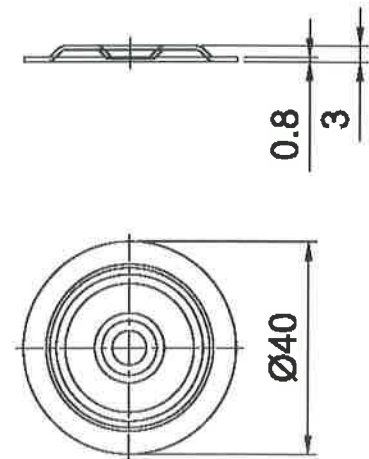

EJOT Flat Roof Fasteners

Combination 34-35:
Fastener: EJOT DABO® VHT - R - 4,8 x L_s / EJOT DABO® VHT - E - 4,8 x L_s
Washer: EJOT® HTV 40 RU

Annex 16

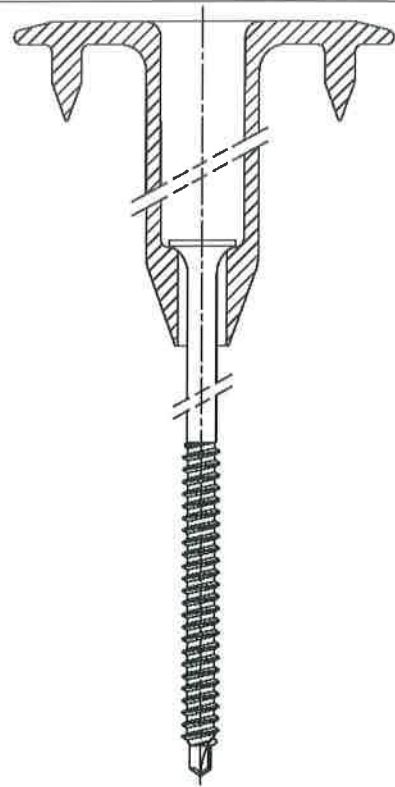
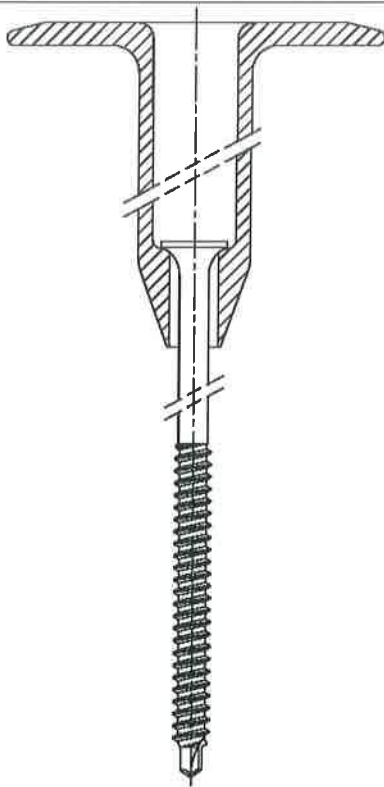

EJOT Dabo® TKR - 4,8 x L_s
EJOT Dabo® TKE - 4,8 x L_s

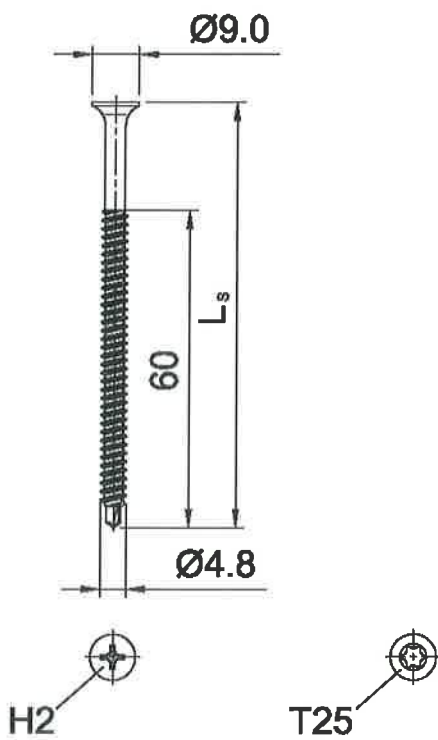

EJOT® EcoTek 50

EJOT® EcoTek T 50

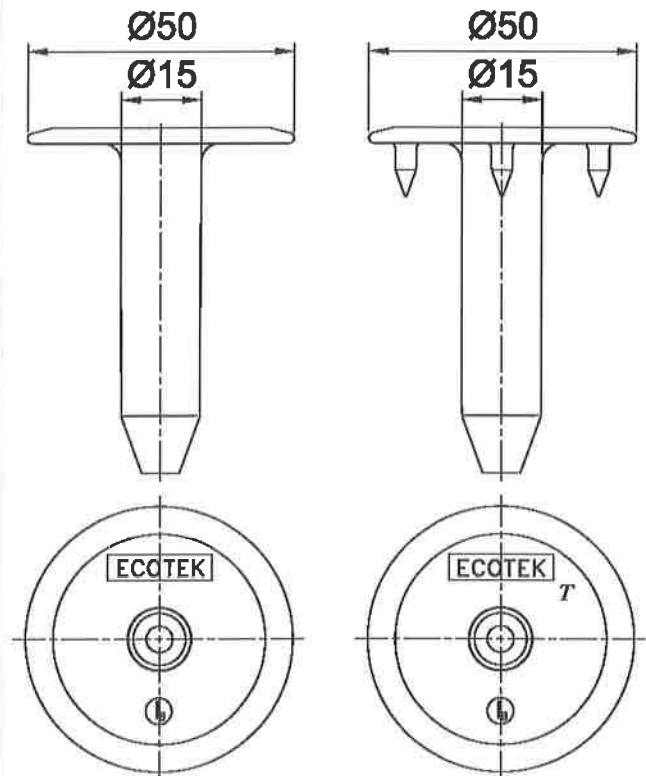

EJOT Flat Roof Fasteners

Combination 36-39:

Fastener: EJOT DABO® TKR - 4,8 x L_s / EJOT DABO® TKE - 4,8 x L_s

Washer: EJOT® EcoTek - 50 / EJOT® EcoTek T - 50

Annex 17

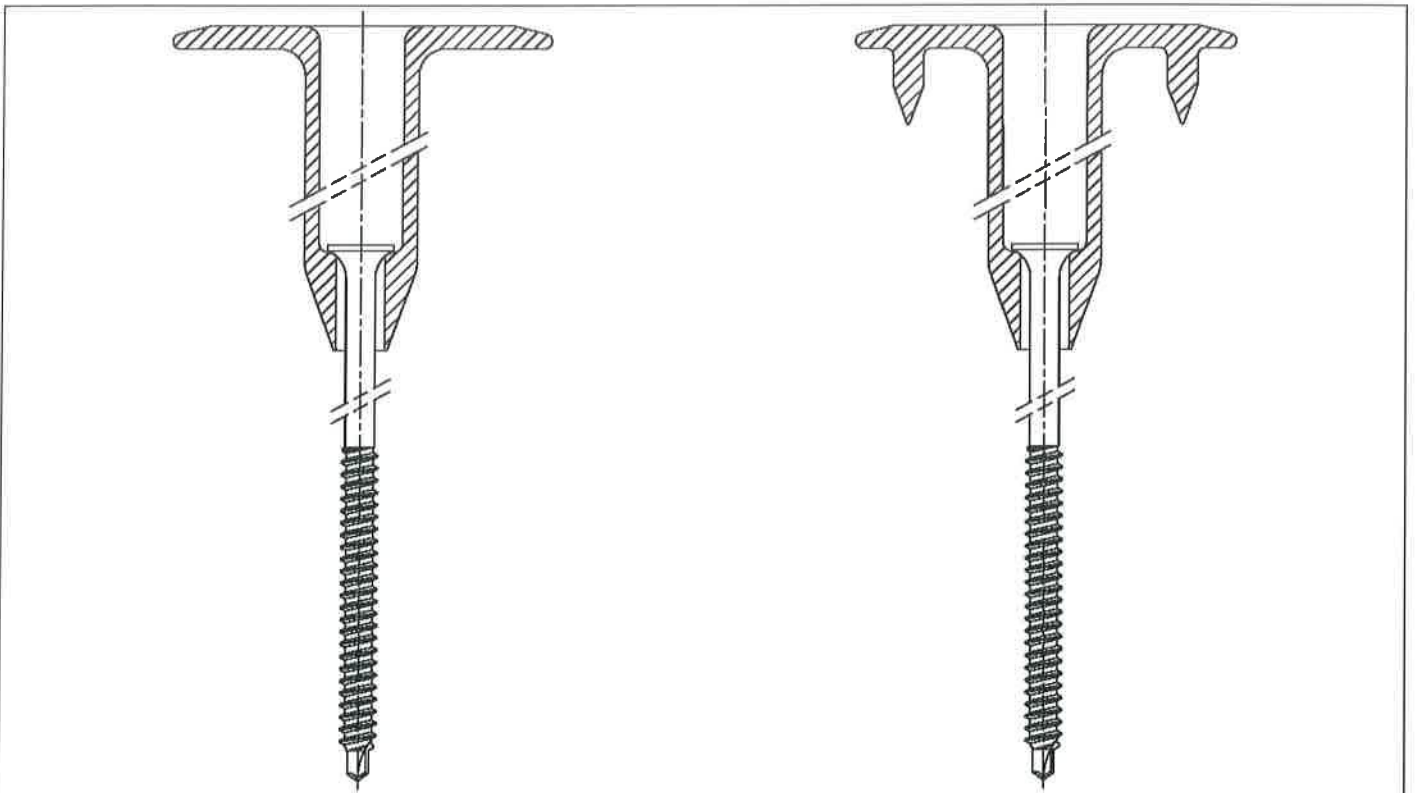

EJOT Dabo® TKR - 4 - 4,8 x L_s

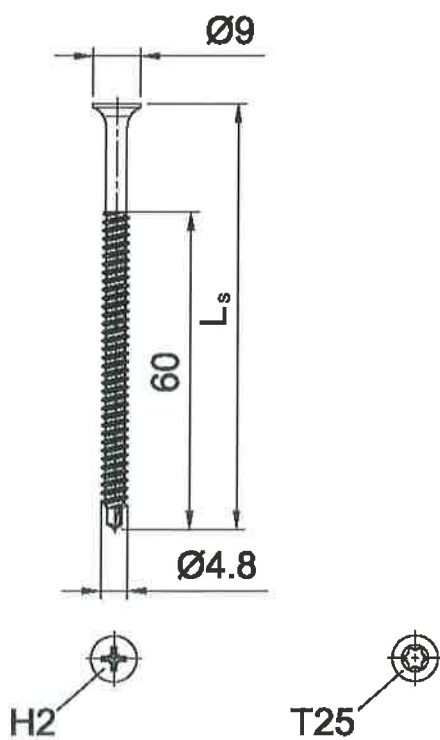

EJOT® EcoTek 50

EJOT® EcoTek T 50

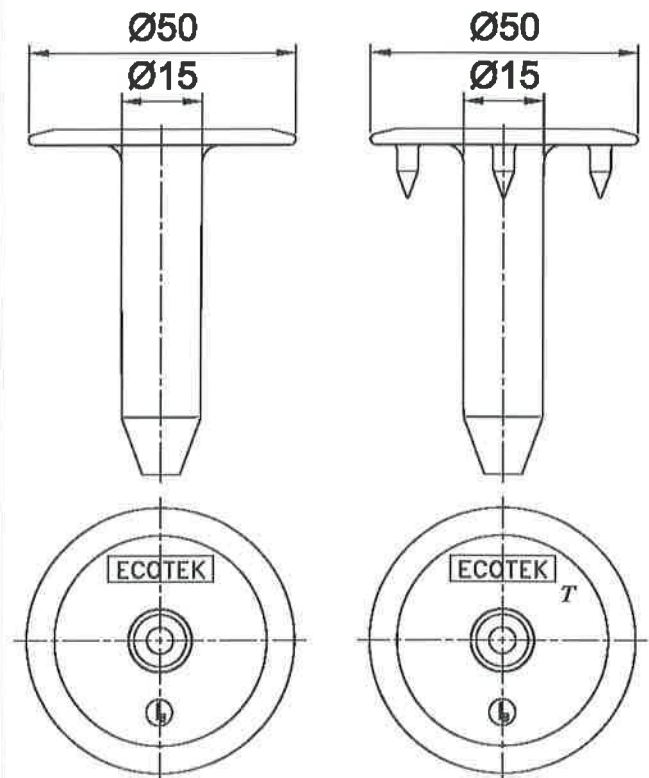

EJOT Flat Roof Fasteners

Combination 40-41:
Fastener: EJOT DABO® TKR - 4 - 4,8 x L_s
Washer: EJOT® EcoTek - 50 / EJOT® EcoTek T - 50

Annex 18

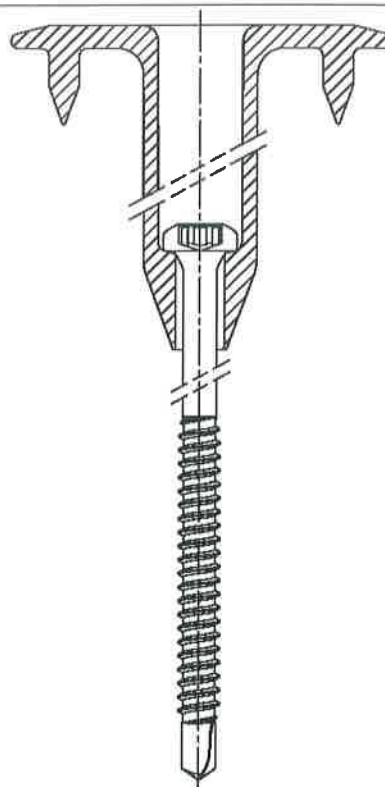
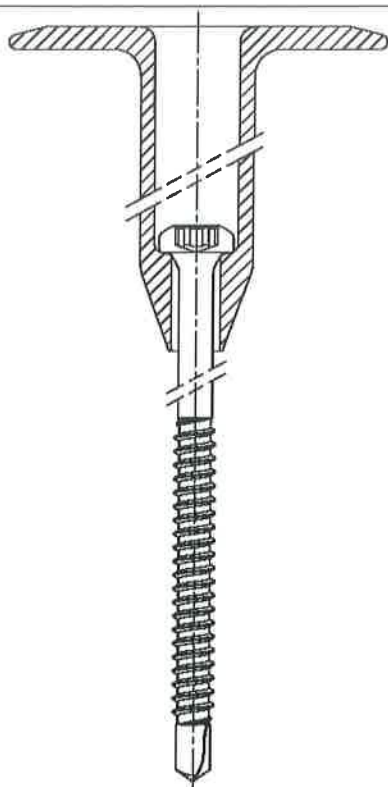

EJOT Dabo® TKR - ZT6 - 5,5 x L_s

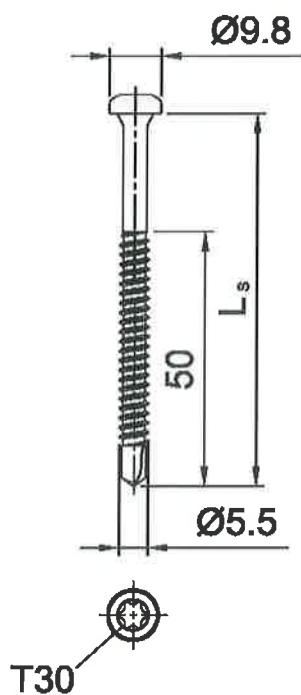

EJOT® EcoTek 50

EJOT® EcoTek T 50

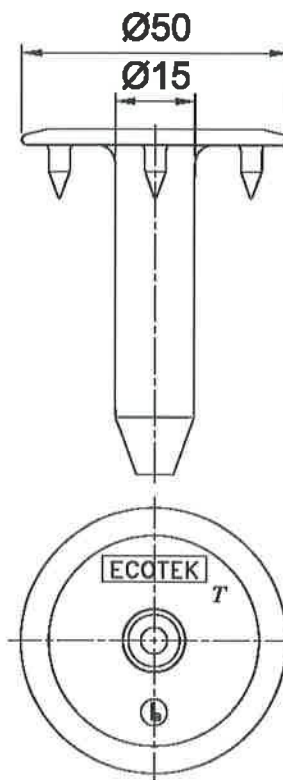
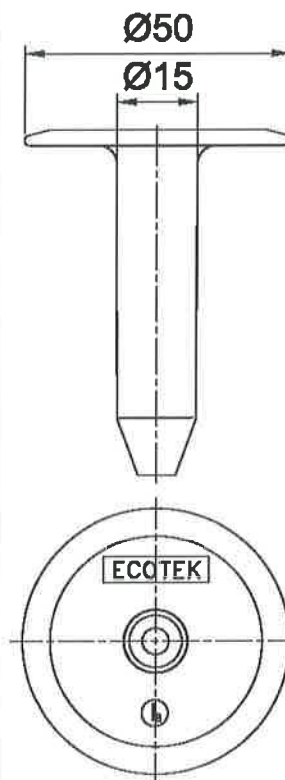

EJOT Flat Roof Fasteners

Combination 42-43:
Fastener: EJOT DABO® TKR – ZT6 – 5,5 x L_s
Washer: EJOT® EcoTek – 50 / EJOT® EcoTek T – 50

Annex 19

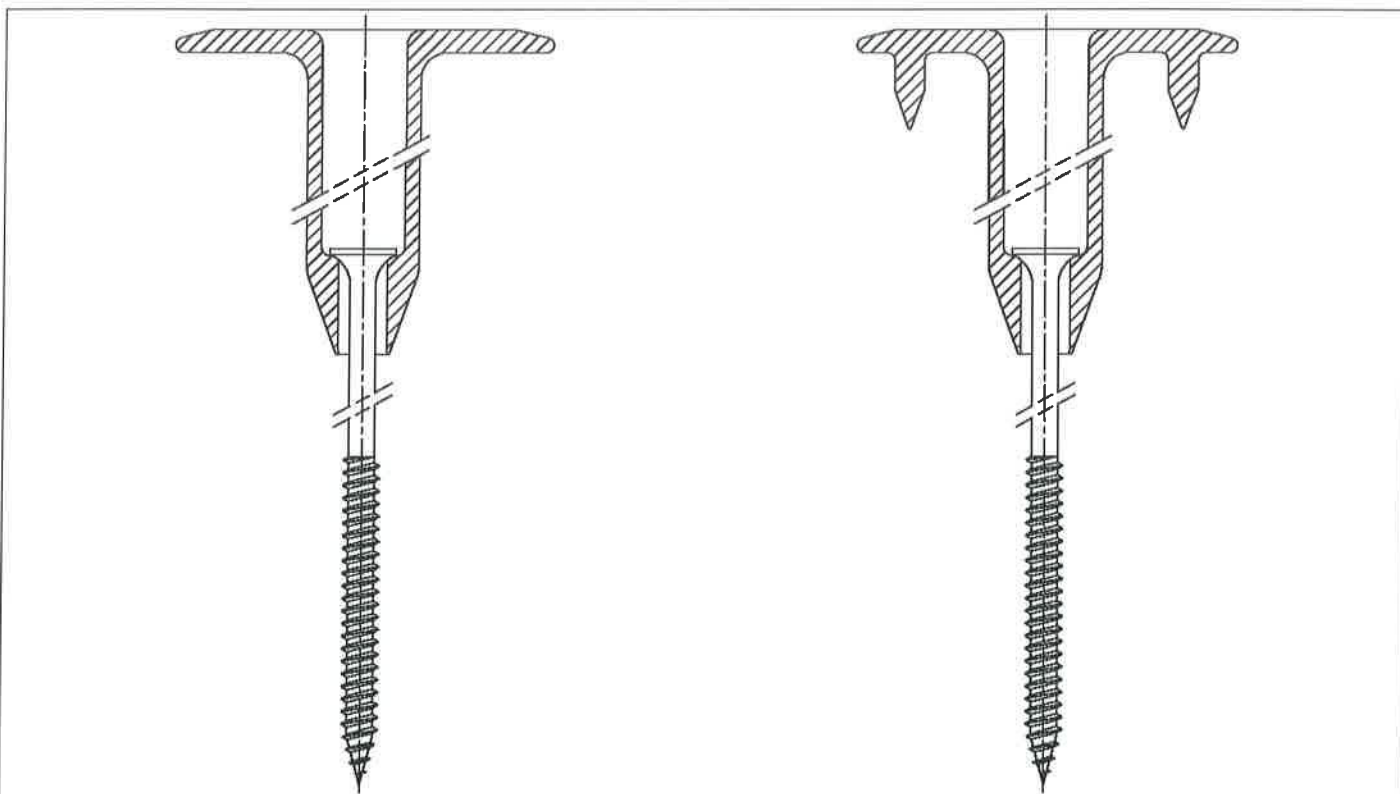

EJOT Dabo® VHT - R - 4,8 x L_s
EJOT Dabo® VHT - E - 4,8 x L_s

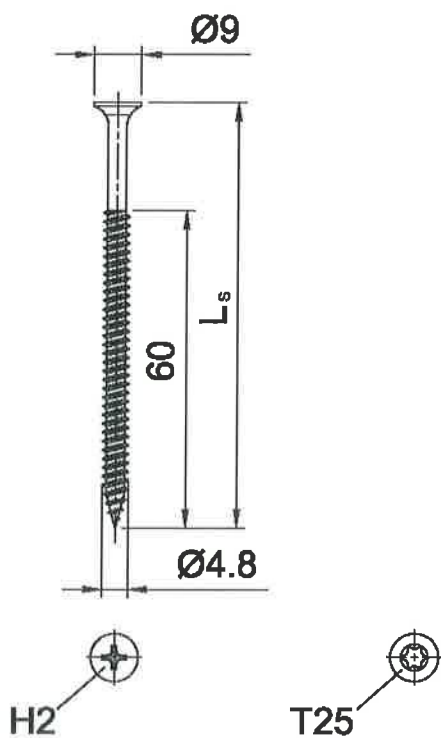

EJOT® EcoTek 50 EJOT® EcoTek T 50

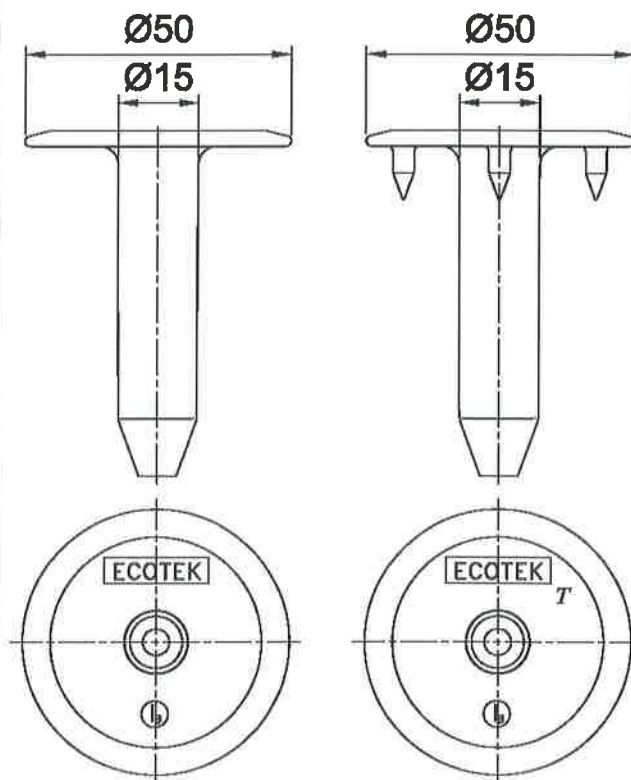

EJOT Flat Roof Fasteners

Combination 44-47:

Fastener: EJOT DABO® VHT - R - 4,8 x L_s / EJOT DABO® VHT - E - 4,8 x L_s

Washer: EJOT® EcoTek - 50 / EJOT® EcoTek T - 50

Annex 20

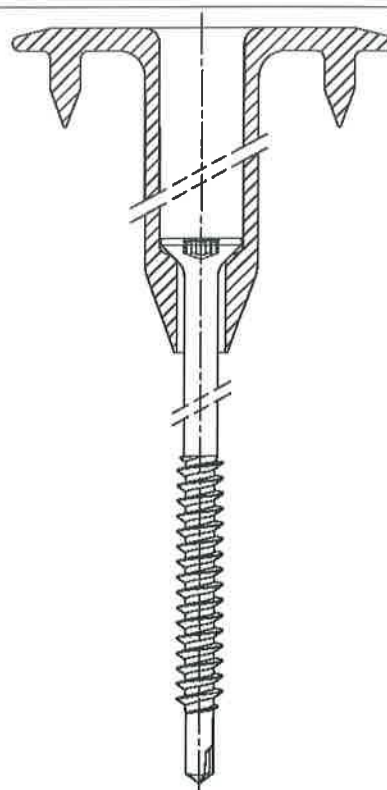
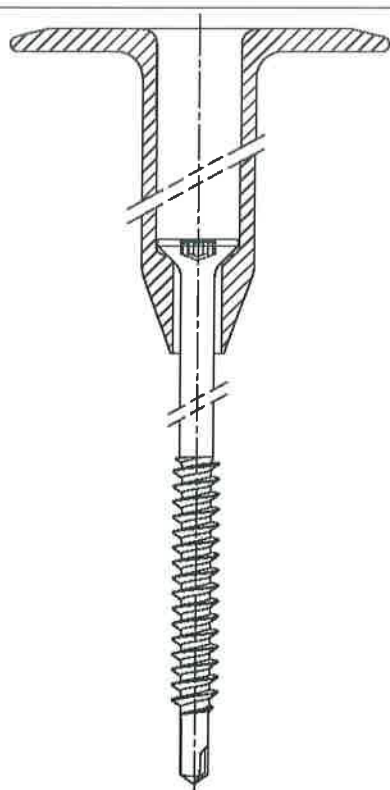

EJOT® JT2 - ST - 2 - 6,0 x L_s
EJOT® JT3 - ST - 2 - 6,0 x L_s

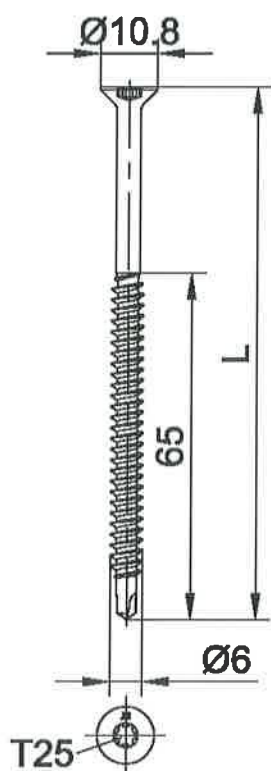

EJOT® EcoTek 50 EJOT® EcoTek T 50

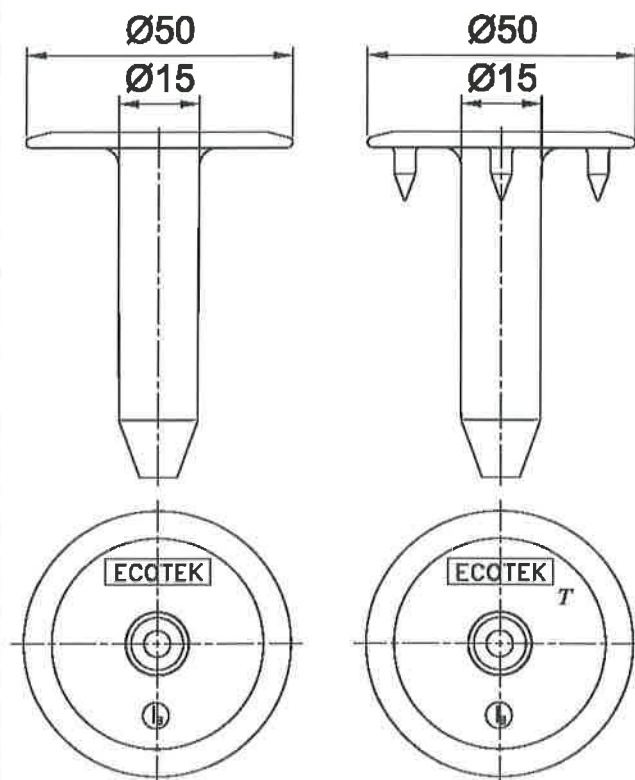

EJOT Flat Roof Fasteners

Combination 48-51:
Fastener: EJOT® JT2 - ST - 2 - 6,0 x L_s / EJOT® JT2 - ST - 2 - 6,0 x L_s
Washer: EJOT® EcoTek - 50 / EJOT® EcoTek T - 50

Annex 21

EJOT® HTV RU 40 / L - W

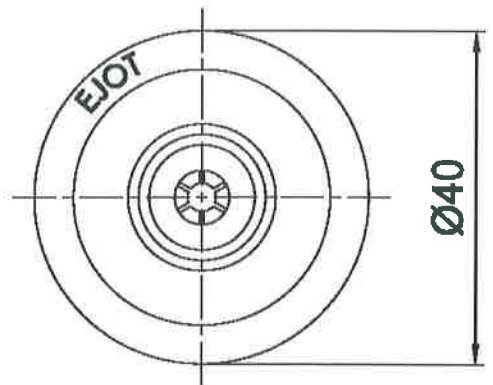
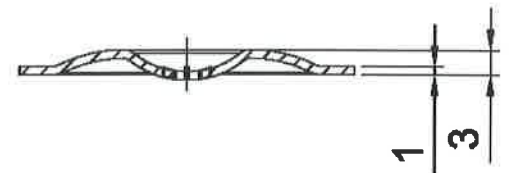
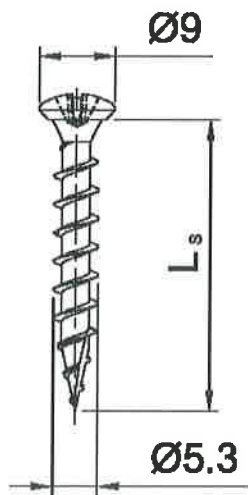
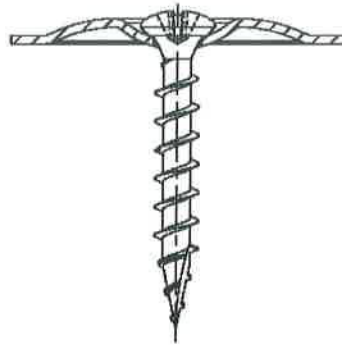

EJOT Flat Roof Fasteners

Combination 52:
Washer: EJOT® HTV RU 40 / L_s - W

Annex 22

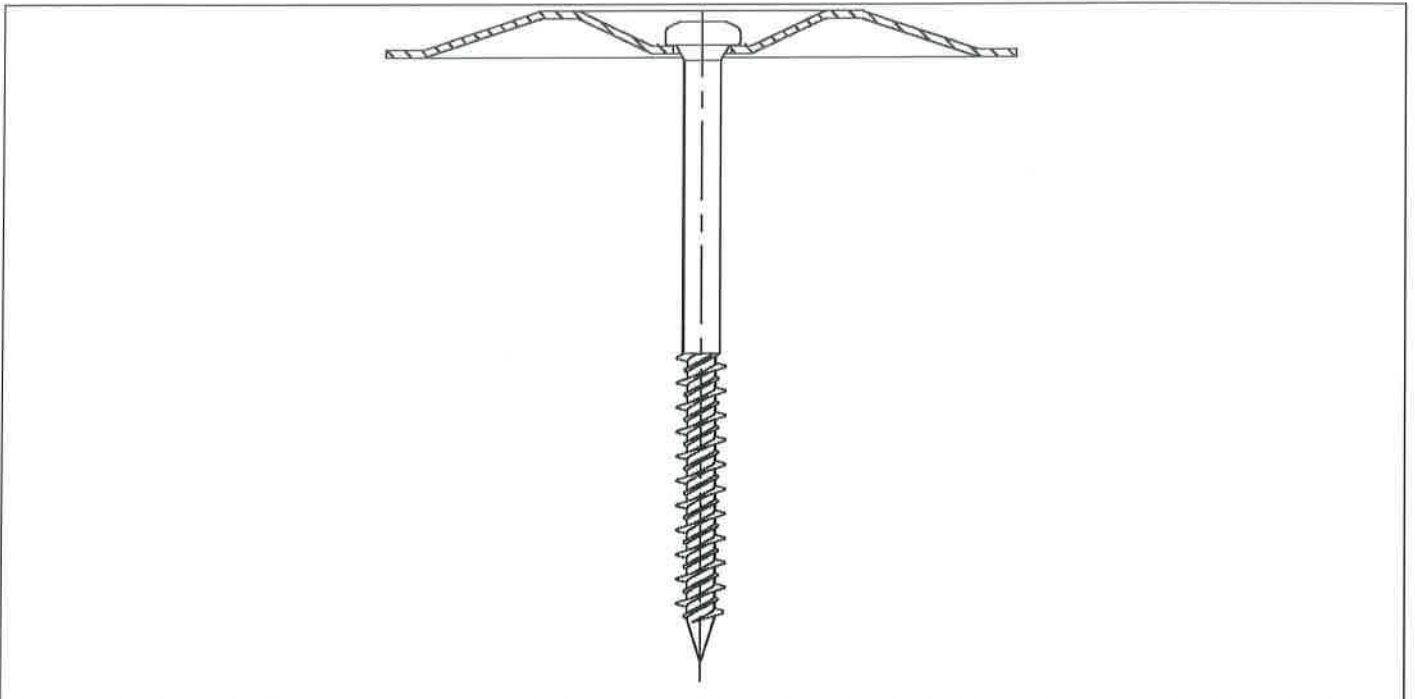

EJOT® FBS - R - 6,3 x L_s

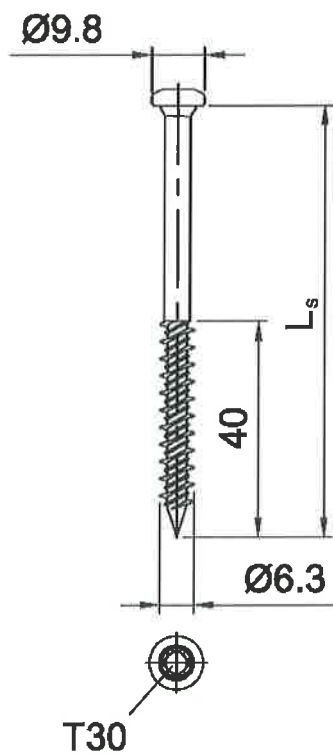

EJOT HTV 82/40 F

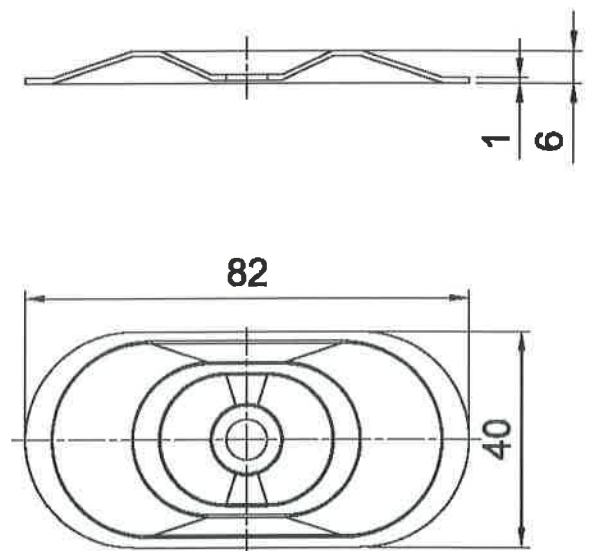

EJOT Flat Roof Fasteners

Combination 53:
Fastener: EJOT® FBS - R - 6,3 x L_s
Washer: EJOT® HTV 82/40 F

Annex 23

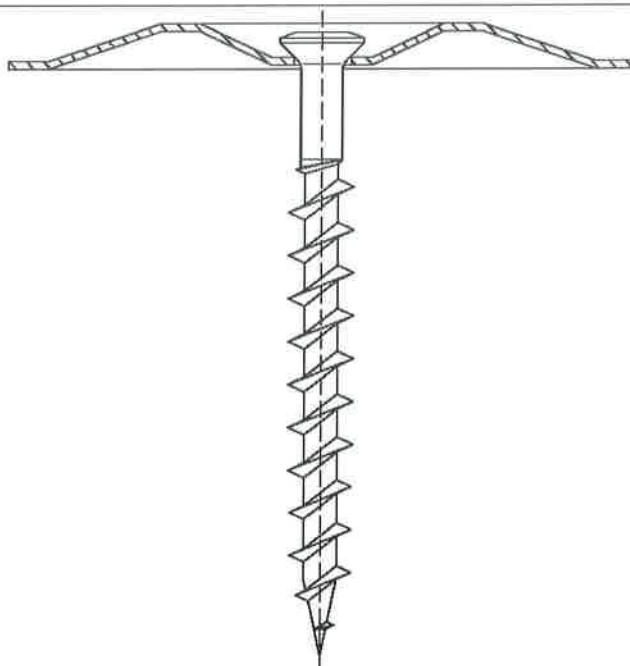

EJOT® FPS - E - 8,0 x L_s

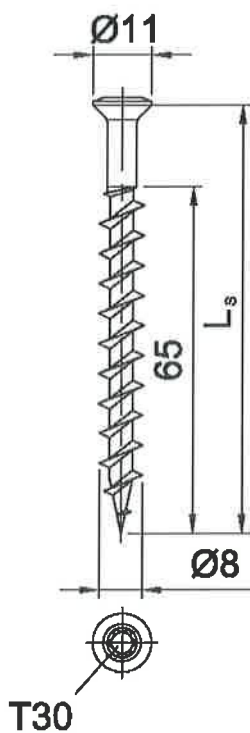

EJOT HTV 82/40 F

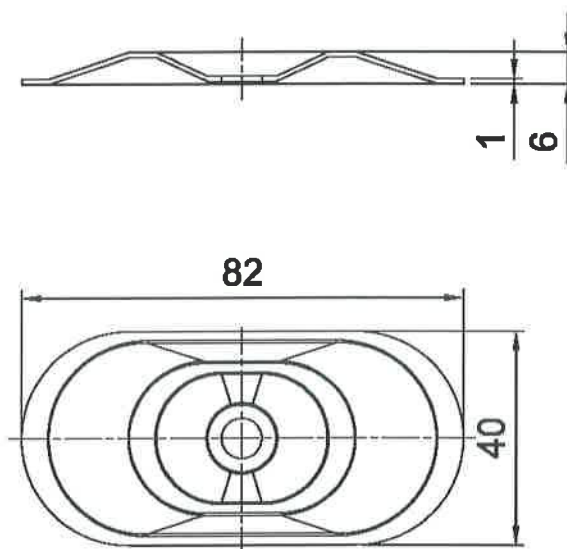

EJOT Flat Roof Fasteners

Combination 54:
Fastener: EJOT® FPS - E - 8,0 x L_s
Washer: EJOT® HTV 82/40 F

Annex 24

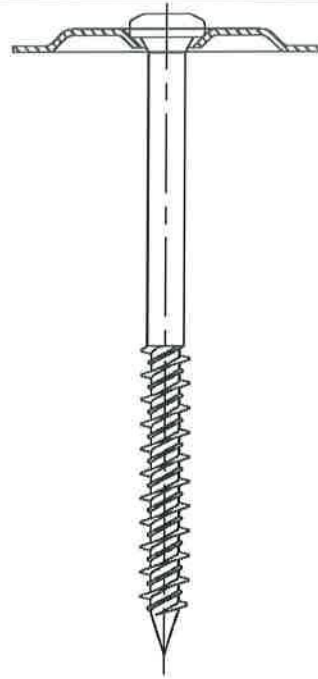

EJOT® FBS - R - 6,3 x L_s

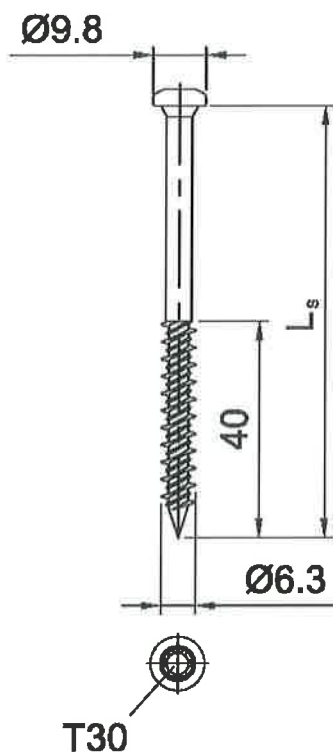

EJOT® HTV 40 RU 6,5

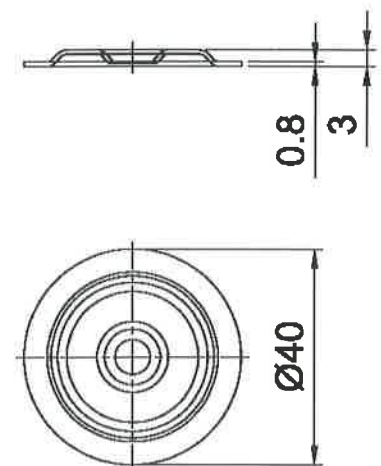

EJOT Flat Roof Fasteners

Combination 55:
Fastener: EJOT® FBS - R - 6,3 x L_s
Washer: EJOT® HTV 82/40 RU

Annex 25

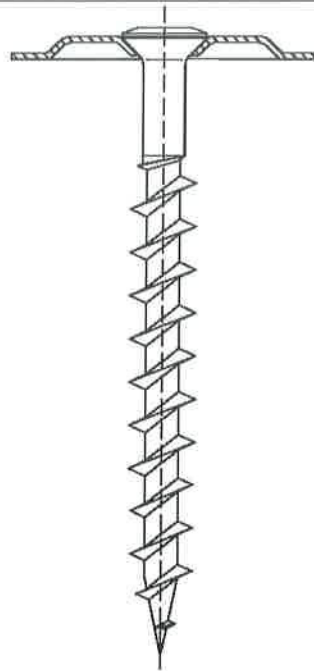

EJOT® FPS - E - 8,0 x L_s

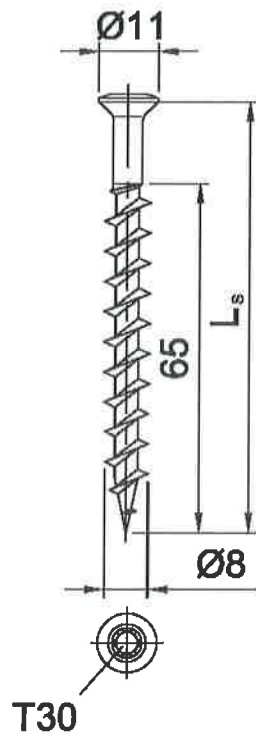

EJOT® HTV 40 RU 6,5

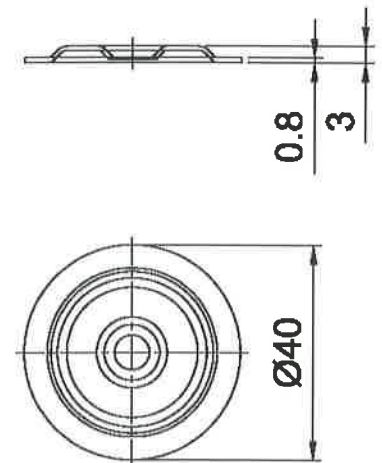

EJOT Flat Roof Fasteners

Combination 56:
Fastener: EJOT® FPS - E - 8,0 x L_s
Washer: EJOT® HTV 82/40 RU

Annex 26

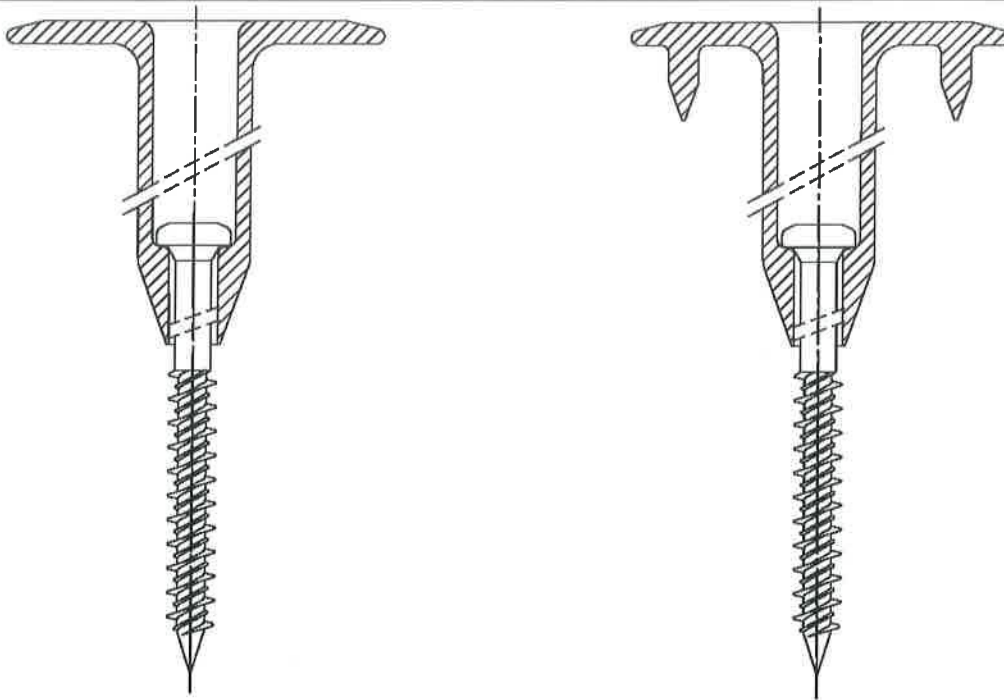

EJOT® FBS - R - 6,3 x L_s

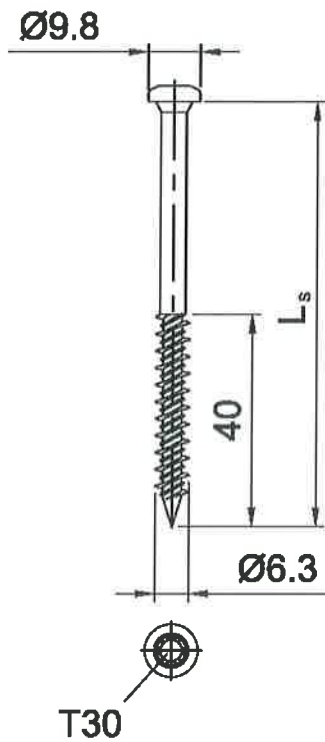

EJOT® EcoTek 50

EJOT® EcoTek T 50

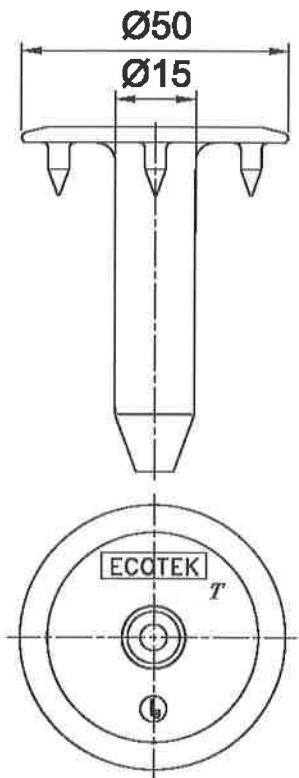
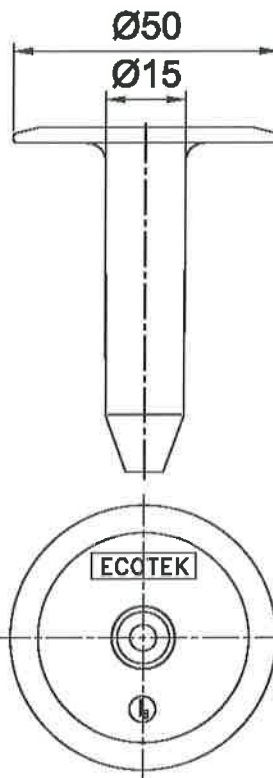

EJOT Flat Roof Fasteners

Combination 57-58:
 Fastener: EJOT® FBS - R - 6,3 x L_s
 Washer: EJOT® EcoTek - 50 / EJOT® EcoTek T - 50

Annex 27

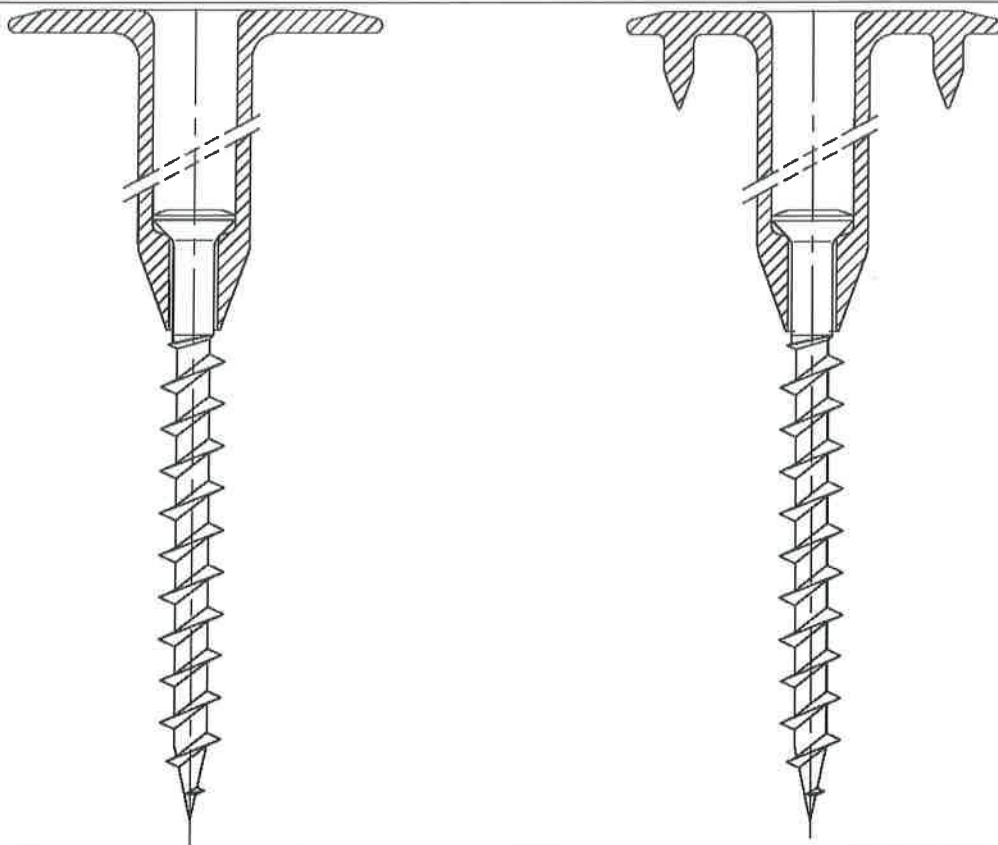

EJOT® FPS - E - 8,0 x L_s

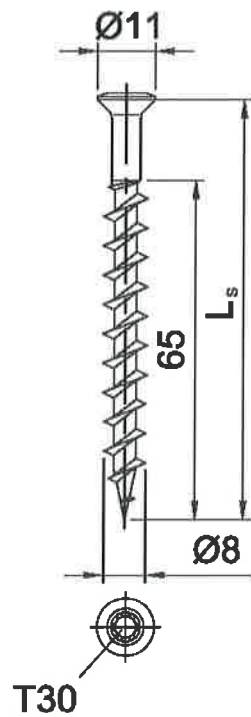

EJOT® EcoTek 50 EJOT® EcoTek T 50

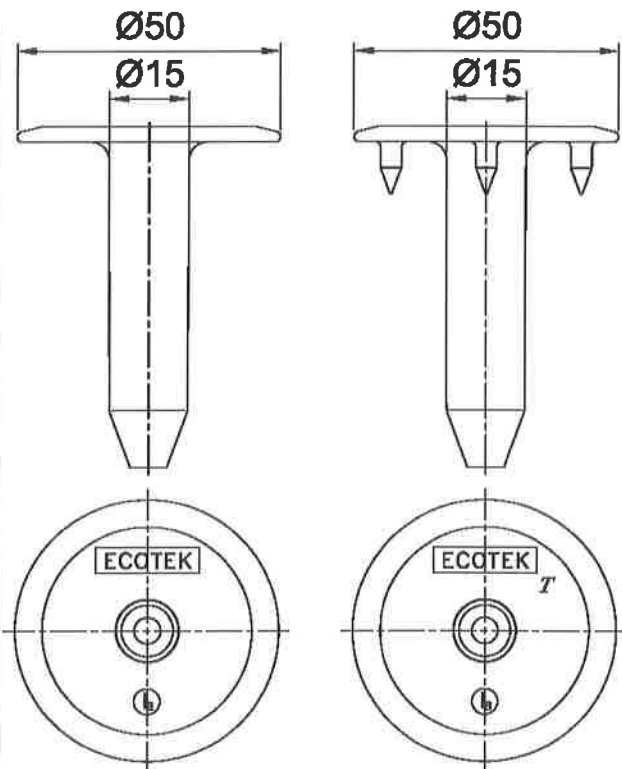

EJOT Flat Roof Fasteners

Combination 59-60:
Fastener: EJOT® FPS – E – 8,0 x L_s
Washer: EJOT® EcoTek – 50 / EJOT® EcoTek T – 50

Annex 28

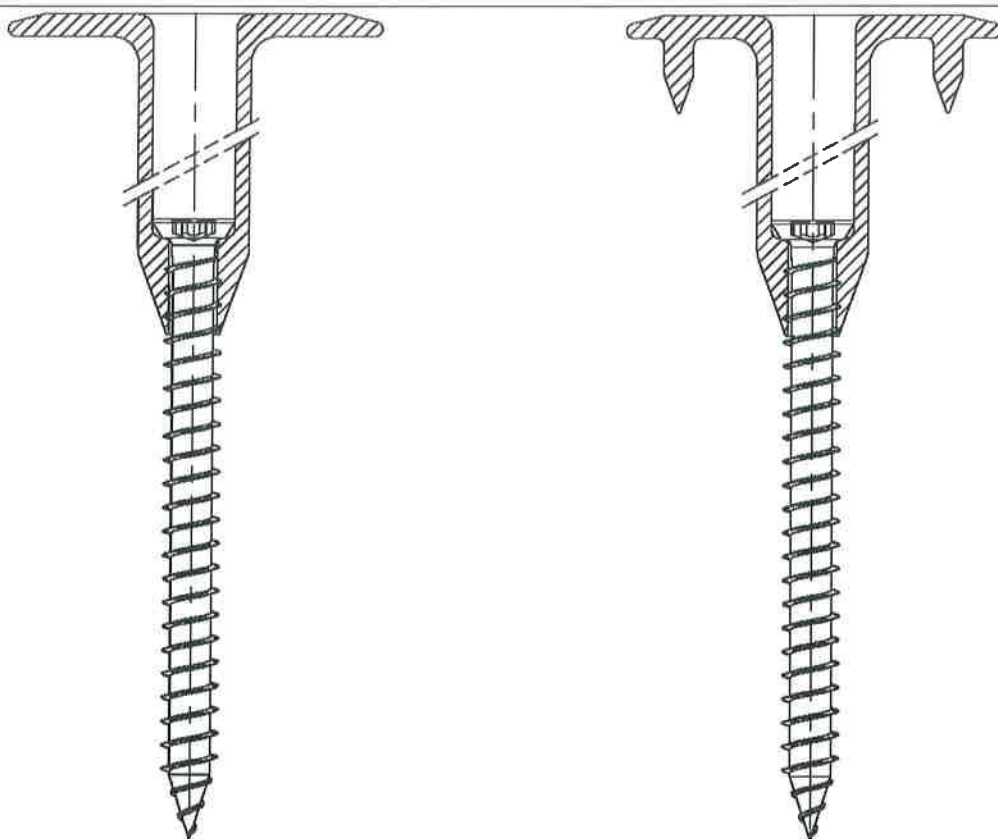

EJOT® JBS - R - 7,5 x L_s

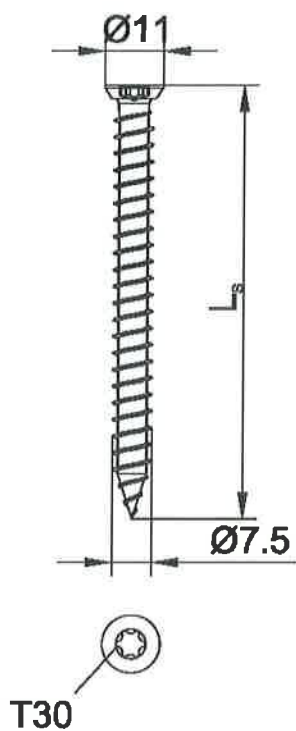

EJOT® EcoTek 50 EJOT® EcoTek T 50

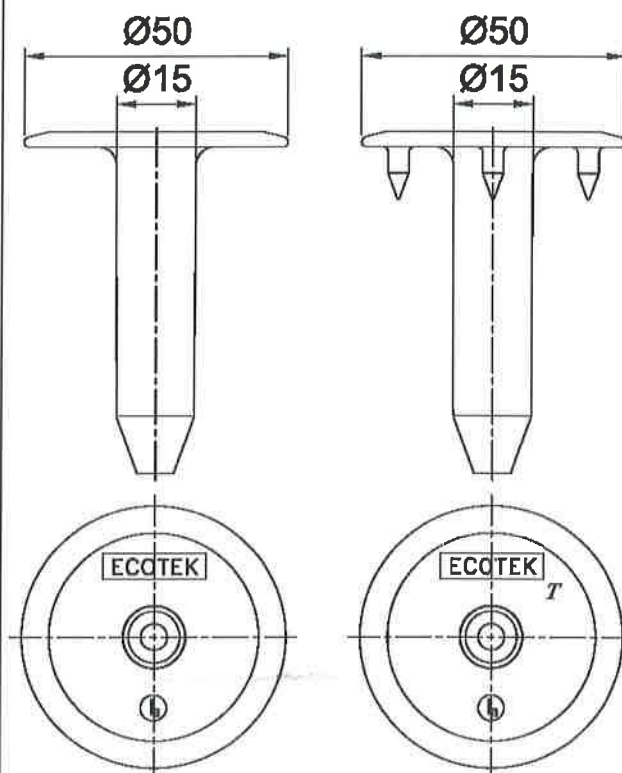

EJOT Flat Roof Fasteners

Combination 61-62:
Fastener: EJOT® JBS - R - 7,5 x L_s
Washer: EJOT® EcoTek - 50 / EJOT® EcoTek T - 50

Annex 29

EJOT® FDD plus 50 x L_D - R
EJOT® FDD plus 50 x L_D - E

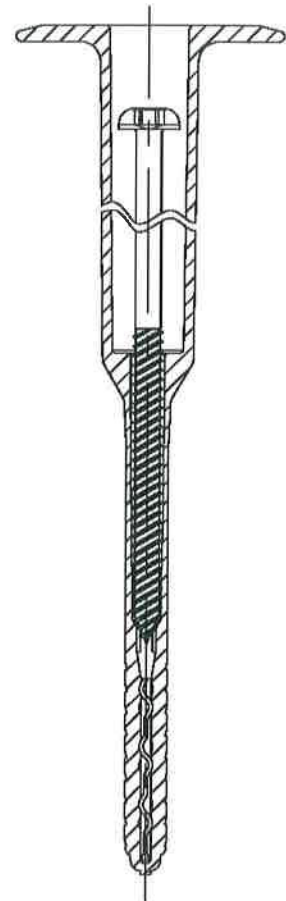
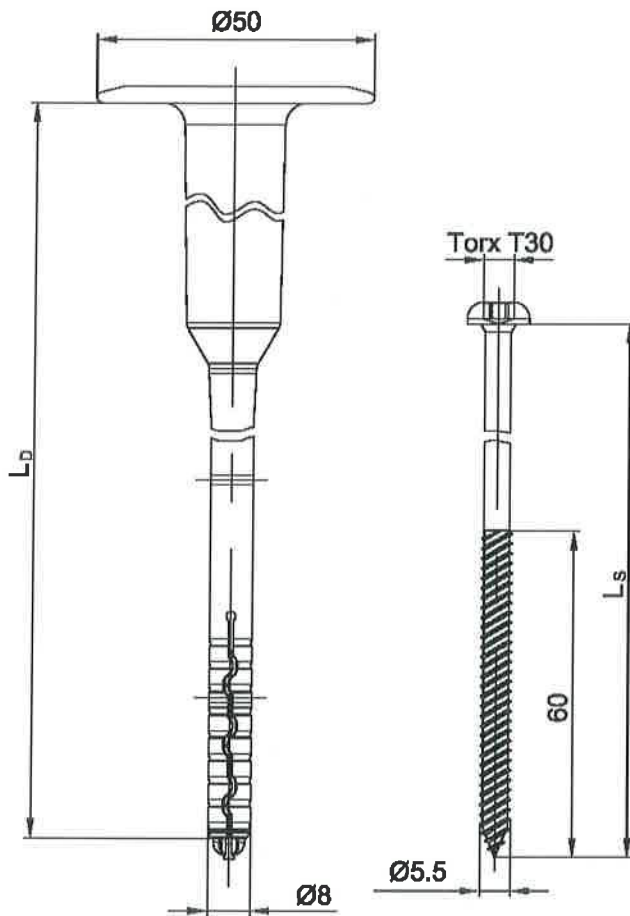

EJOT Flat Roof Fasteners

Combination 63-64:
Fastener: EJOT® FDDplus 50 x L_D - R / EJOT® FDDplus 50 x L_D - E (one-piece)

Annex 30

EJOT® FDD plus 50 x L_D - R
EJOT® FDD plus 50 x L_D - E

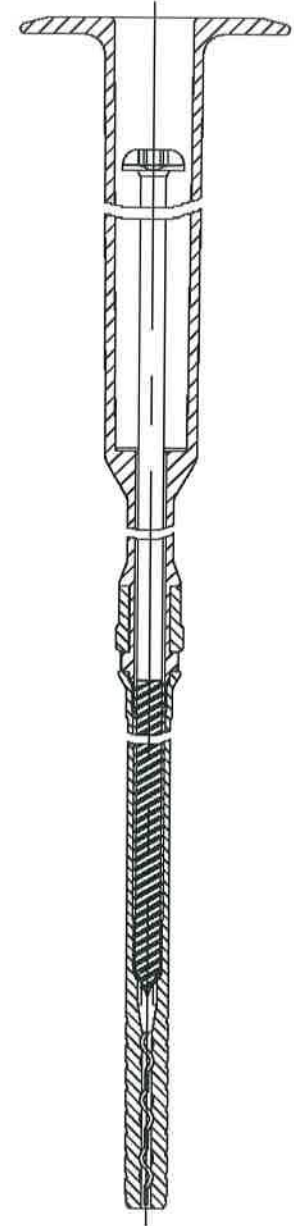
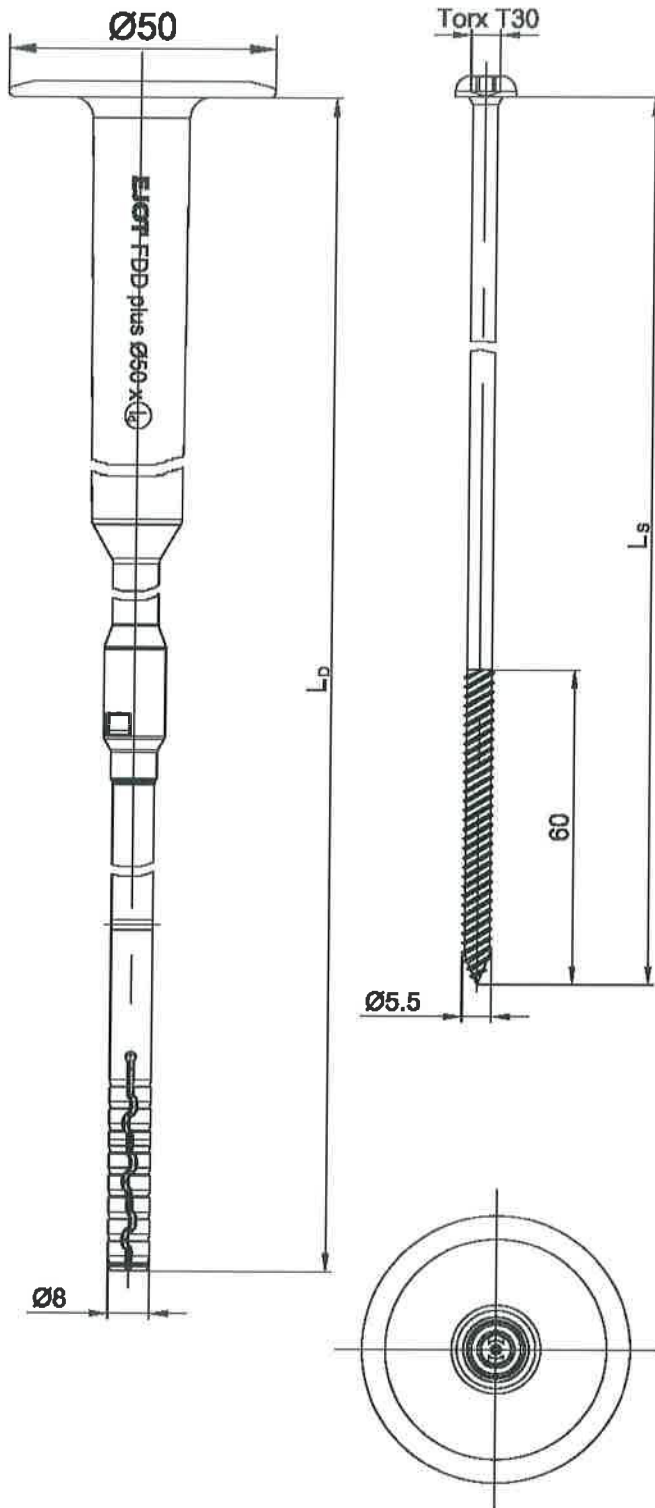

EJOT Flat Roof Fasteners

Combination 65-66:
Fastener: EJOT® FDDplus 50 x L_D - R / EJOT® FDDplus 50 x L_D - E (two-parts)

Annex 31

EJOT® FDD plus "S" 50 x L_D - R
EJOT® FDD plus "S" 50 x L_D - E

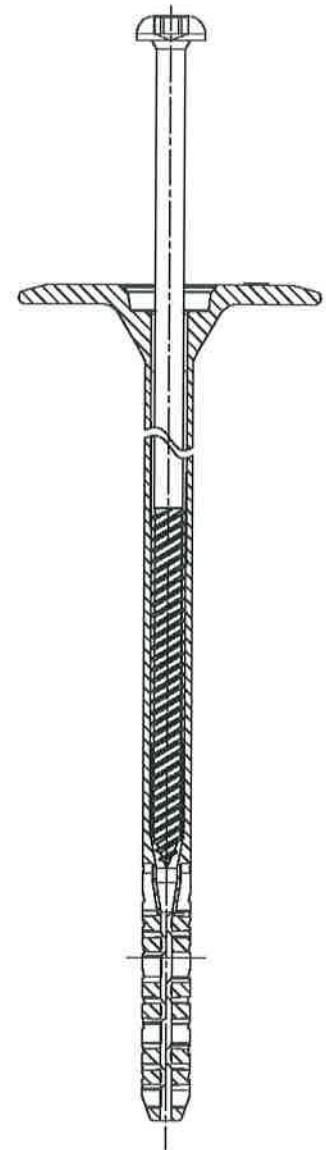
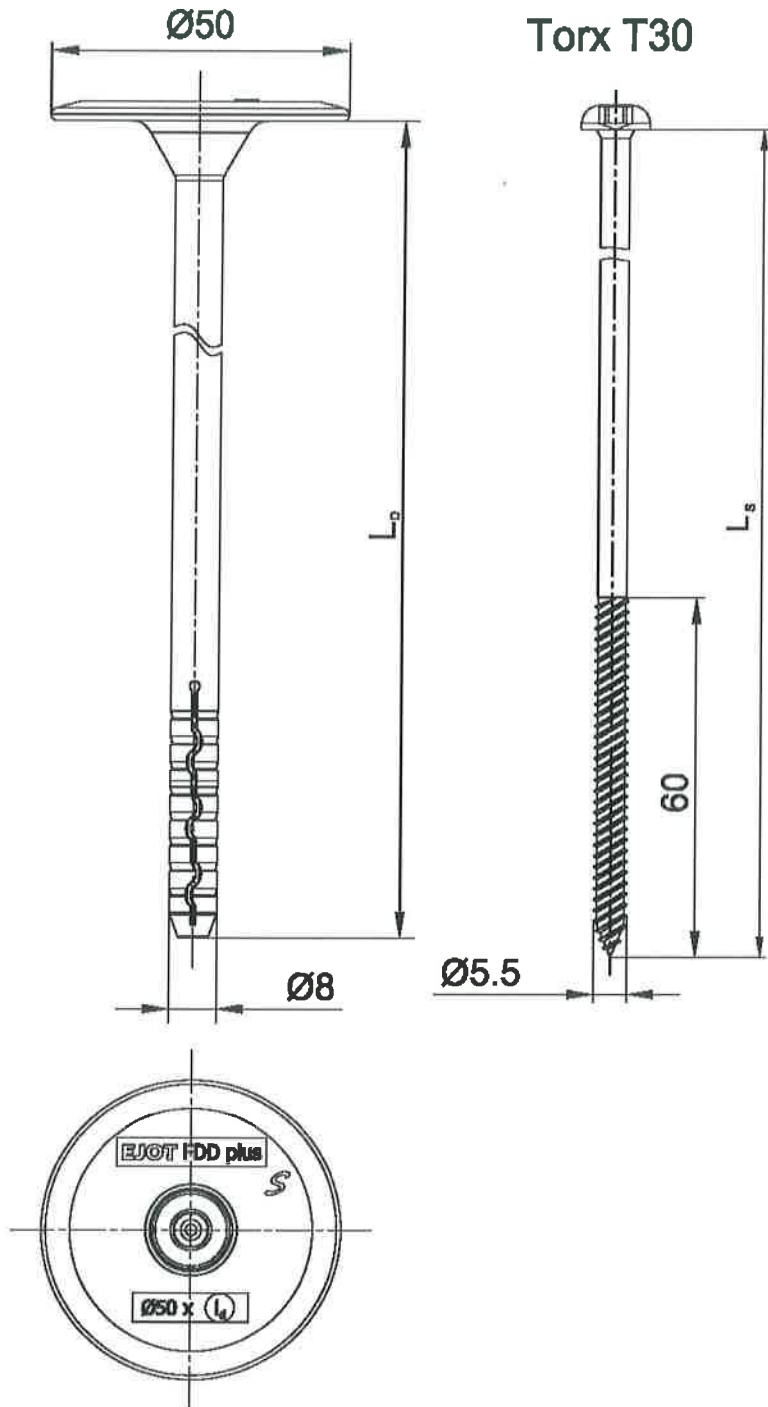

EJOT Flat Roof Fasteners

Combination 67-68:
Fastener: EJOT® FDDplus „S“ 50 x L_D – R / EJOT® FDDplus „S“ 50 x L_D – E

Annex 32

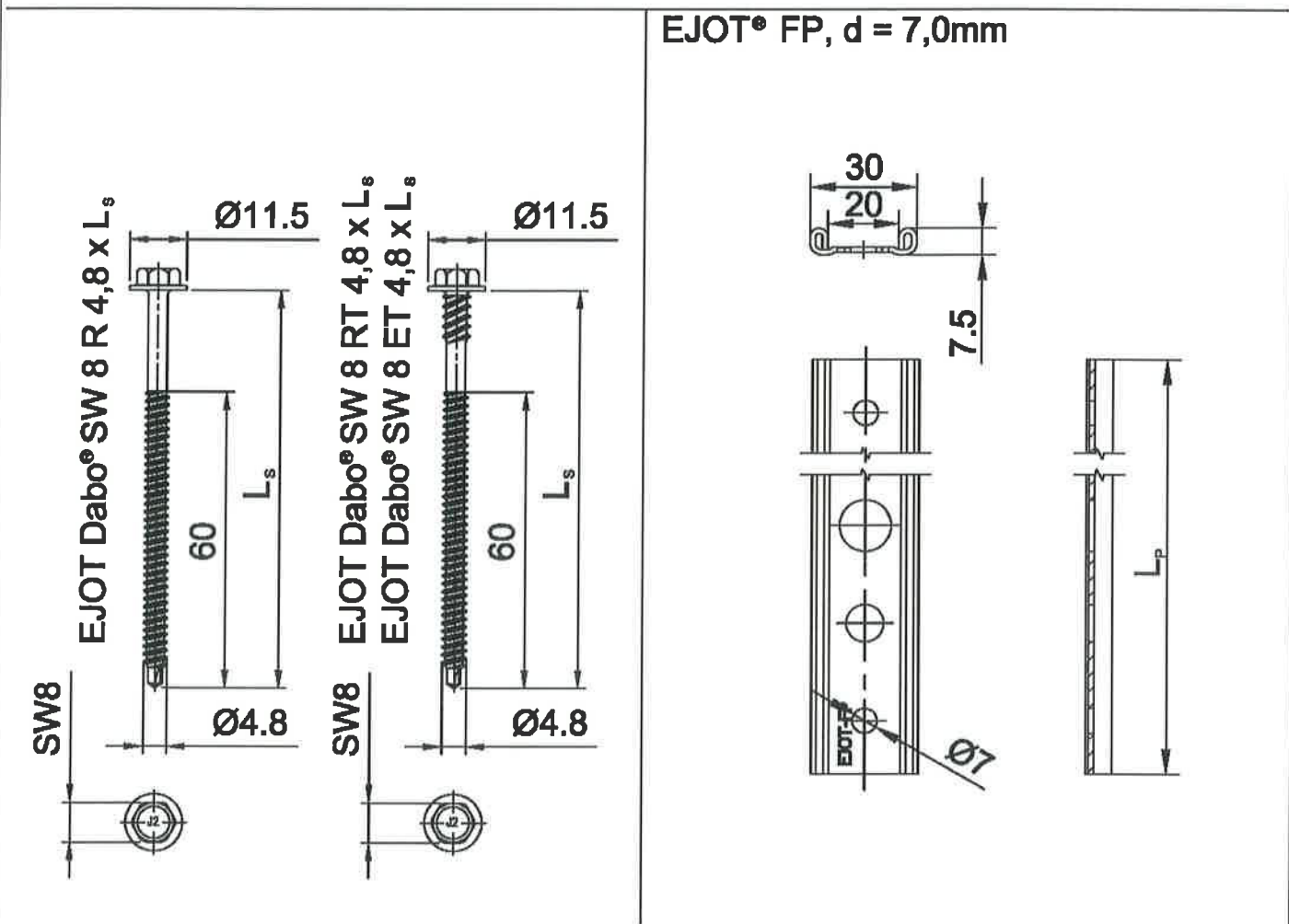
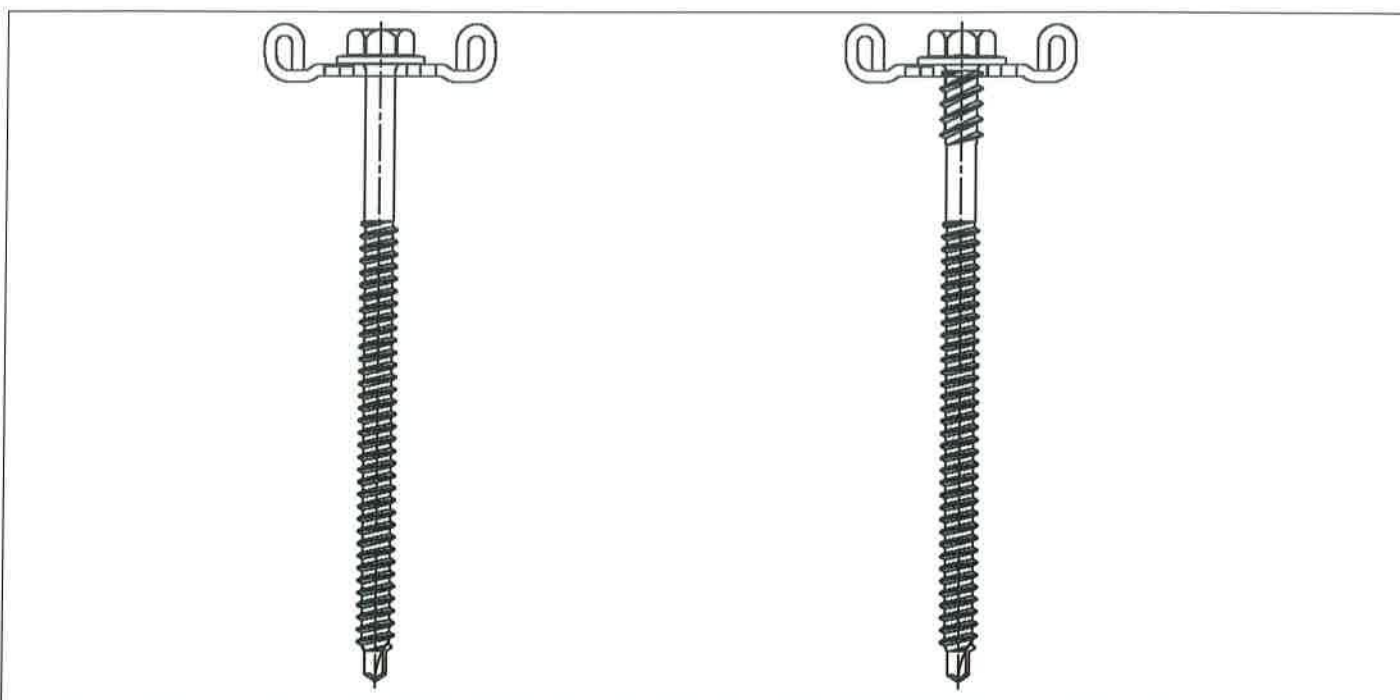

EJOT Flat Roof Fasteners

Combination 69-71:
 Fastener: EJOT DABO® SW 8 R x L_s / DABO® SW 8 RT x L_s / DABO® SW 8 ET x L_s
 Washer: EJOT® FP

Annex 33

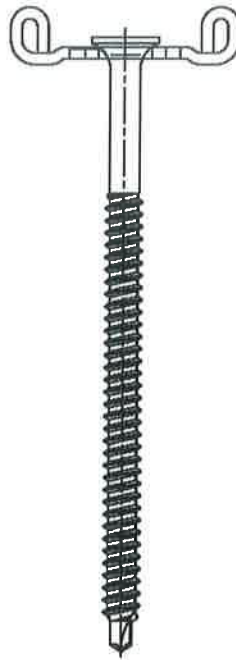

EJOT Dabo® TKR - 4,8 x L_s
EJOT Dabo® TKE - 4,8 x L_s

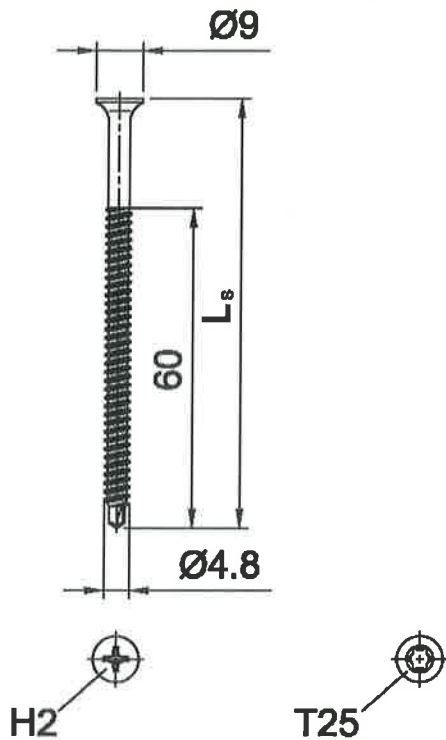

EJOT® FP, d = 7,0mm

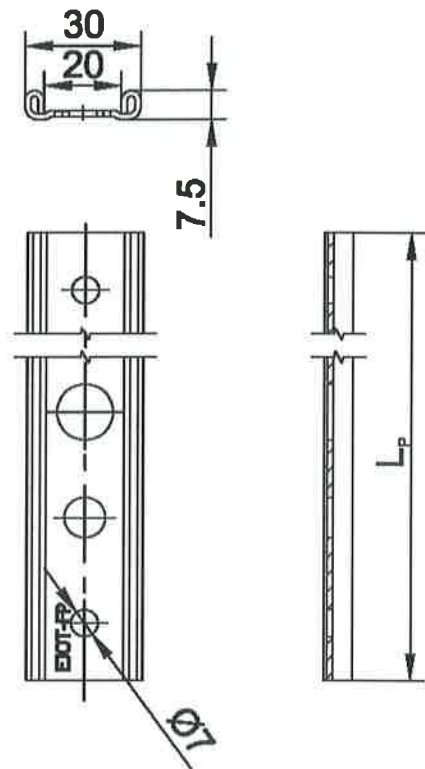

EJOT Flat Roof Fasteners

Combination 72-73:
Fastener: EJOT DABO® TKR – 4,8 x L_s / EJOT DABO® TKE – 4,8 x L_s
Washer: EJOT® FP

Annex 34



EJOT Dabo® TKR - 4 - 4,8 x L_s

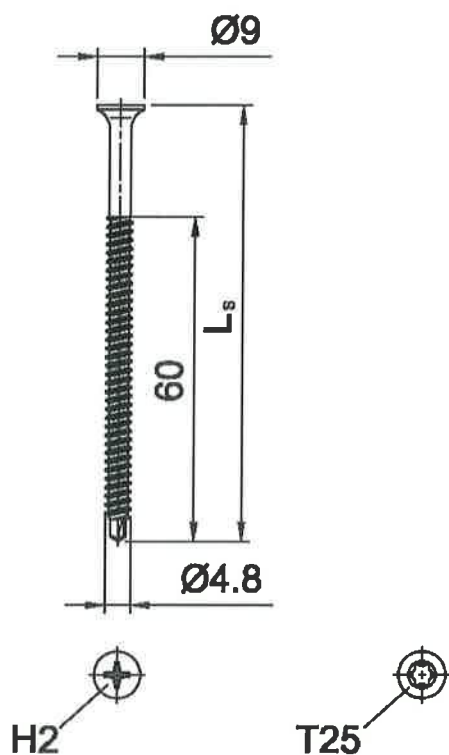

EJOT® FP, d = 7,0mm

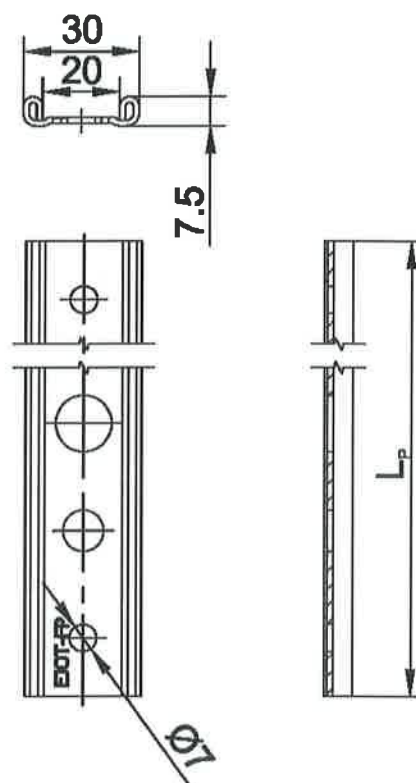

EJOT Flat Roof Fasteners

Combination 74:
Fastener: EJOT DABO® TKR - 4 - 4,8 x L_s
Washer: EJOT® FP

Annex 35

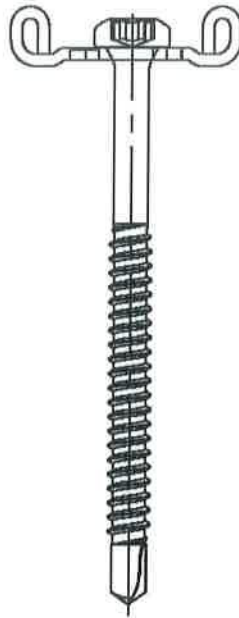

EJOT Dabo® TKR - ZT6 - 5,5 x L_s

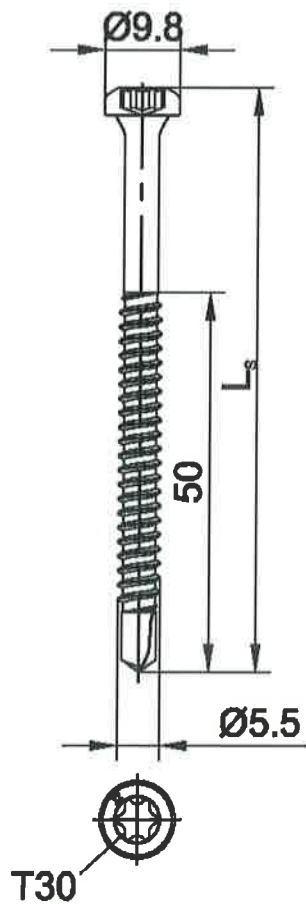

EJOT® FP, d = 7,0mm

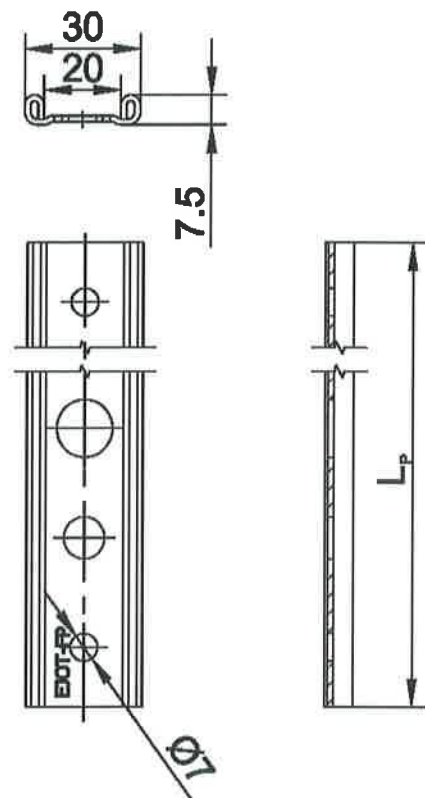

EJOT Flat Roof Fasteners

Combination 75:
Fastener: EJOT DABO® TKR – ZT6 – 5,5 x L_s
Washer: EJOT® FP

Annex 36

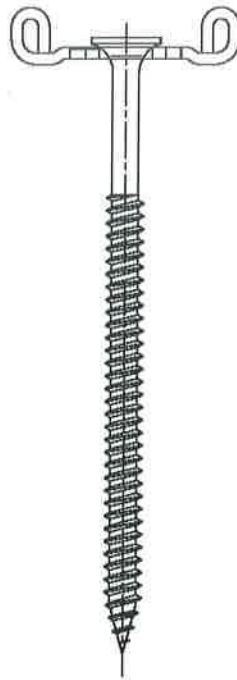

EJOT Dabo® VHT-R - 4,8 x L_s
EJOT Dabo® VHT-E - 4,8 x L_s

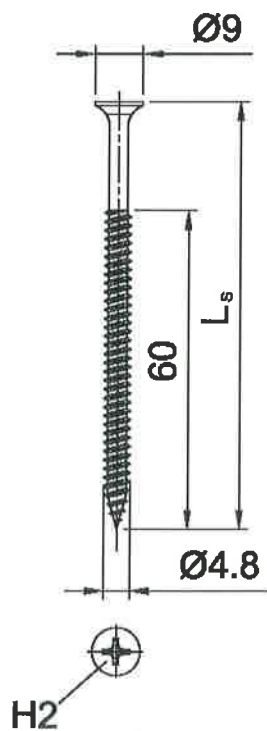

EJOT® FP, d = 7,0mm

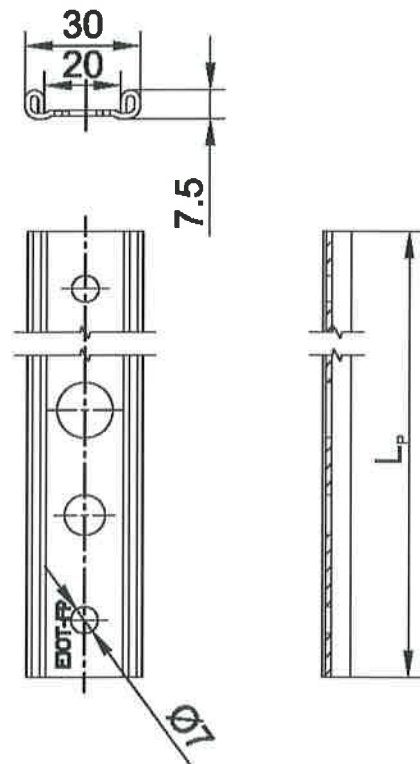

EJOT Flat Roof Fasteners

Combination 76-77:
Fastener: EJOT DABO® VHT-R - 4,8 x L_s / EJOT DABO® VHT-E - 4,8 x L_s
Washer: EJOT® FP

Annex 37

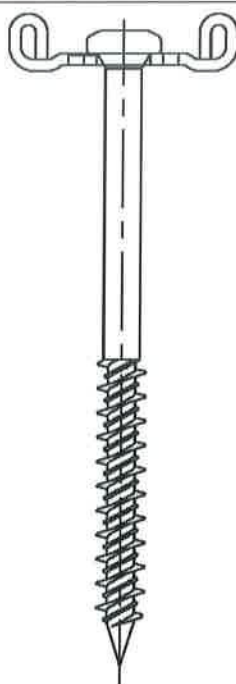

EJOT® FBS - R - 6,3 x L_s

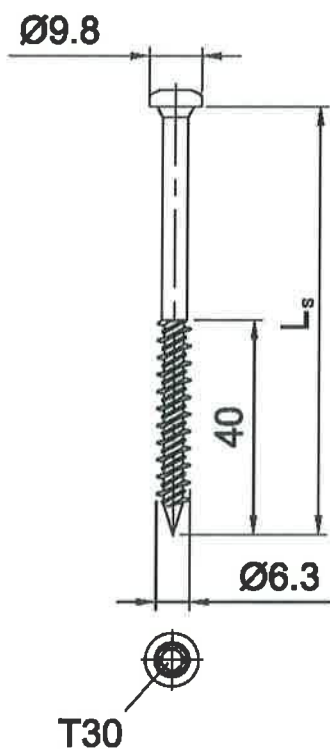

EJOT® FP, d = 7,0mm

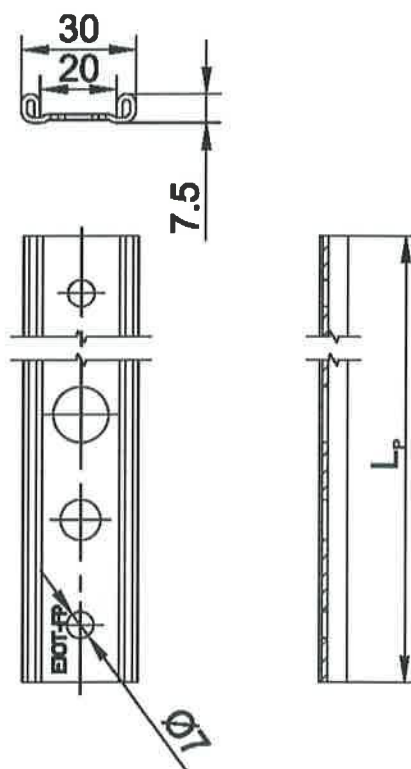

EJOT Flat Roof Fasteners

Combination 78:
Fastener: EJOT® FBS - R - 6,3 x L_s
Washer: EJOT® FP

Annex 38

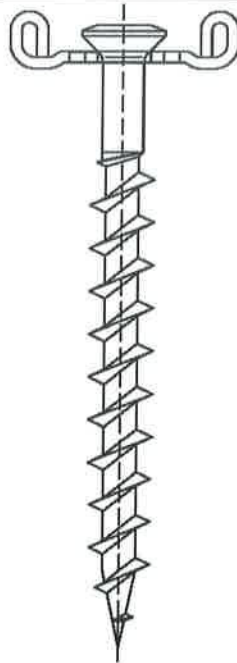

EJOT® FPS - E - 8,0 x L_s

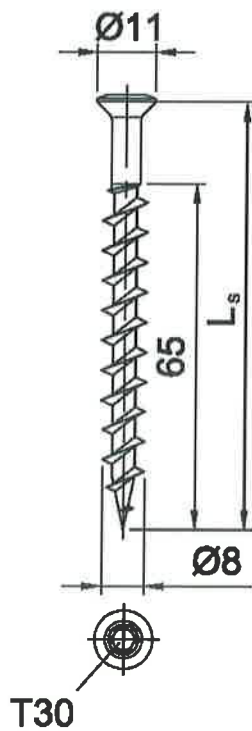

EJOT® FP, d = 7,0mm

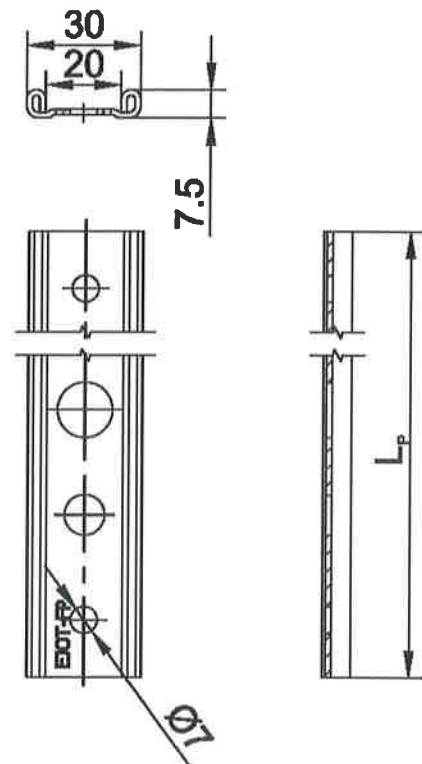

EJOT Flat Roof Fasteners

Combination 79:
Fastener: EJOT® FPS - E - 8,0 x L_s
Washer: EJOT® FP

Annex 39



EJOT JT2® - ST - 2 - 6,0 x L_s
EJOT JT3® - ST - 2 - 6,0 x L_s

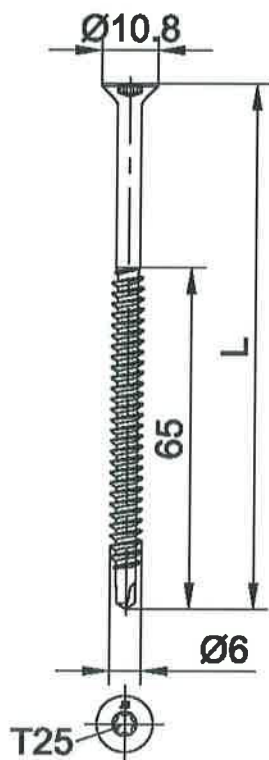

EJOT® FP, d = 7,0mm

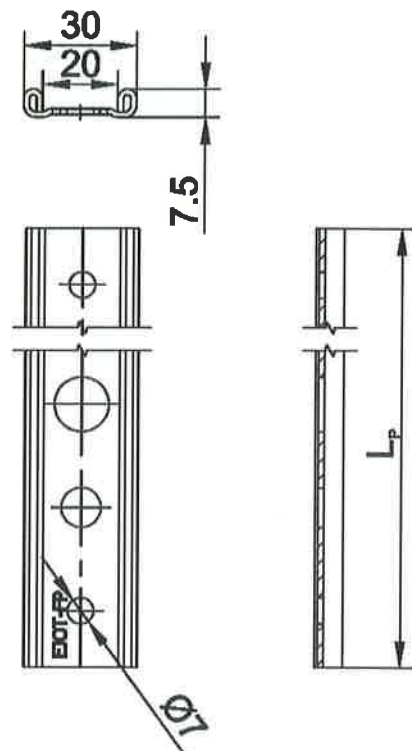

EJOT Flat Roof Fasteners

Combination 80-81:
Fastener: EJOT® JT2 - ST - 2 - 6,0 x L_s / EJOT® JT3 - ST - 2 - 6,0 x L_s
Washer: EJOT® FP

Annex 40



EJOT®JT2 - ST - 2 - 6,8 x L_s

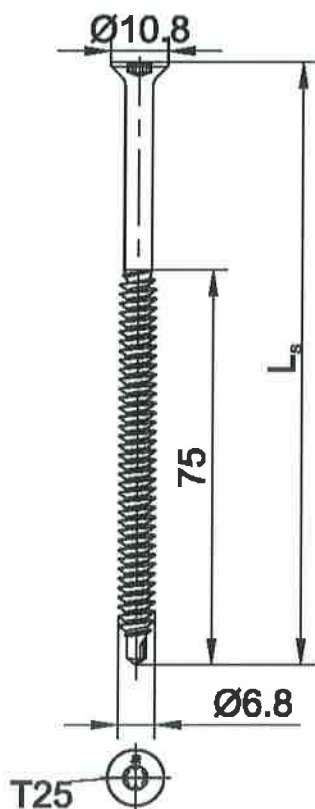

EJOT® FP, d = 7,0mm

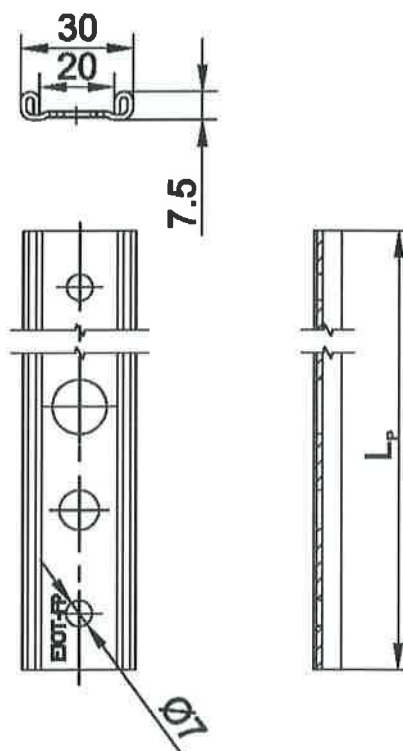

EJOT Flat Roof Fasteners

Combination 82:
Fastener: EJOT® JT2 - ST - 2 - 6,8 x L_s
Washer: EJOT® FP

Annex 41

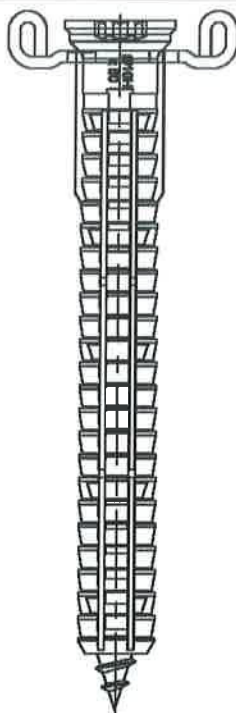

EJOT® SDF-S 10H x L - E

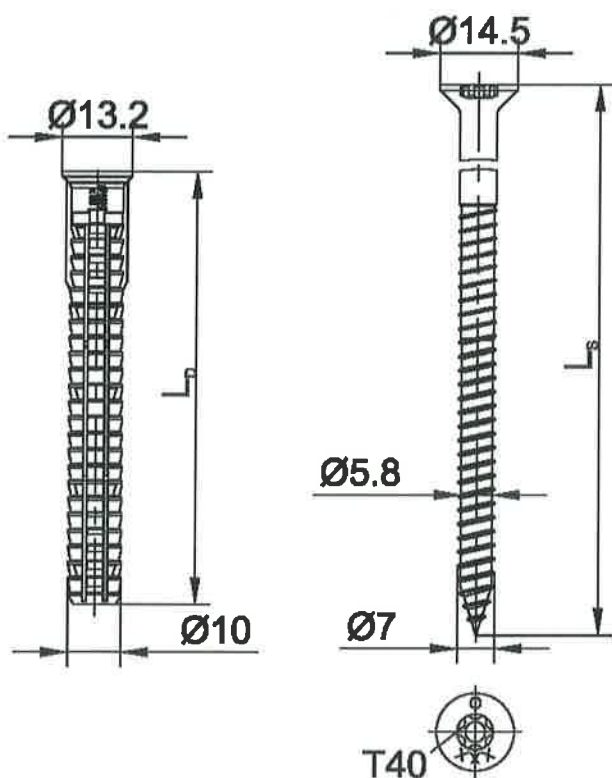

EJOT® FP, d = 10,5mm

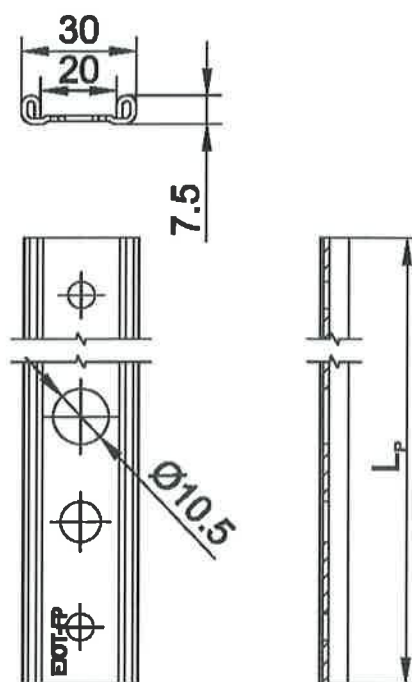

EJOT Flat Roof Fasteners

Combination 83:
Fastener: EJOT® SDF-S 10H x L - E
Washer: EJOT® FP

Annex 42

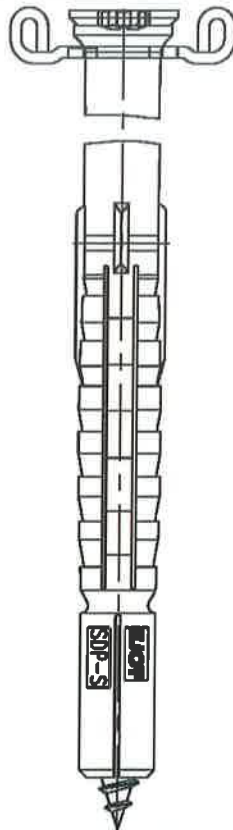

EJOT® SDP-S 10G x L - E

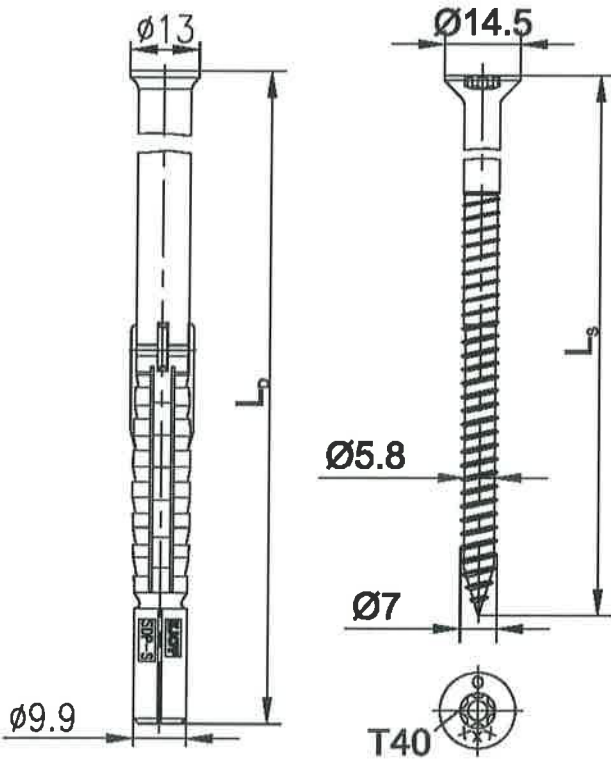

EJOT® FP, d = 10,5mm

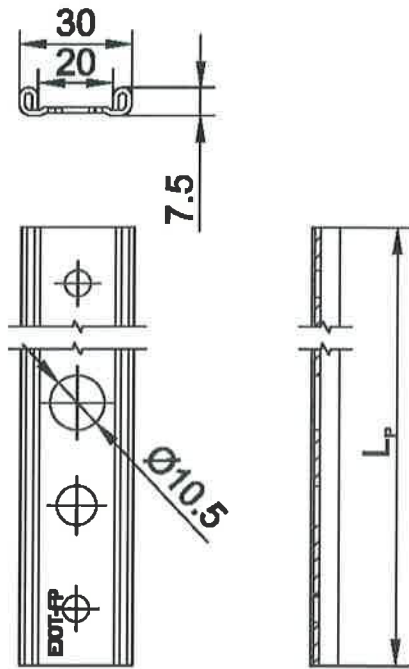

EJOT Flat Roof Fasteners

Combination 84:
Fastener: EJOT® SDP-S 10G x L - E
Washer: EJOT® FP

Annex 43

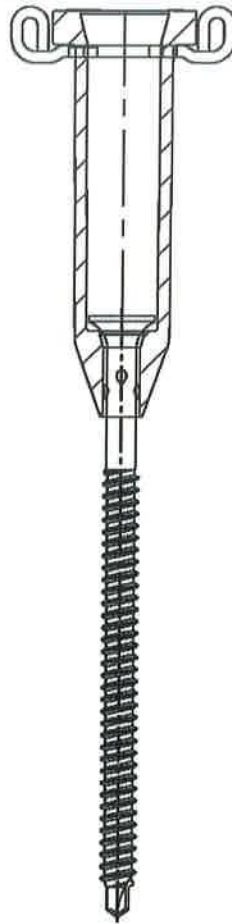

EJOT Dabo® TKR - 4,8 x L_s
EJOT Dabo® TKE - 4,8 x L_s

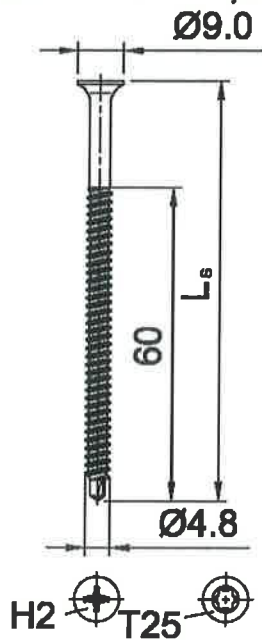

EJOT® FP, d = 14,5mm

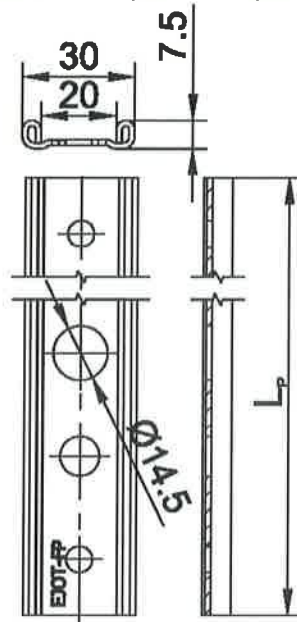

EJOT® HTK-S - 20 x L_B

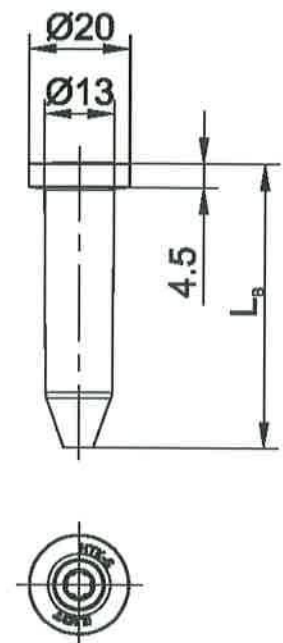

EJOT Flat Roof Fasteners

Combination 85-86:

Fastener: EJOT DABO® TKR - 4,8 x L_s / EJOT DABO® TKE - 4,8 x L_s

Washer: EJOT® FP with EJOT® HTK-S - 20 x L_B

Annex 44

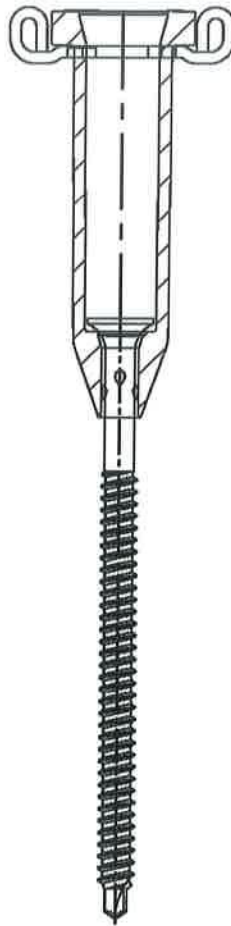

EJOT Dabo® TKR-4-4,8xL_s

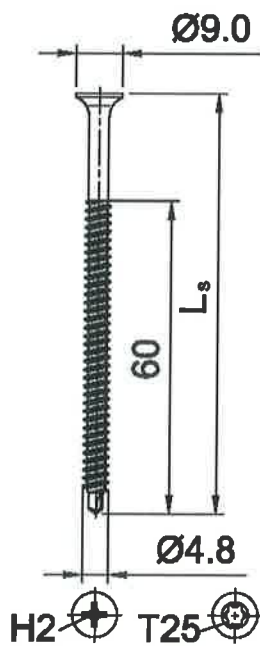

EJOT® FP, d = 14,5mm

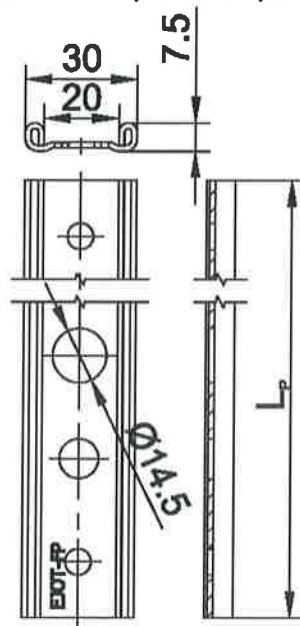

EJOT® HTK-S - 20 x L_s

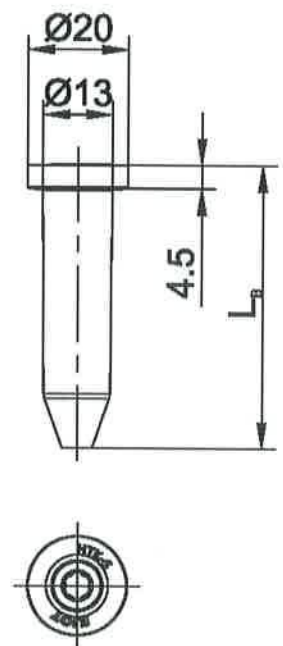

EJOT Flat Roof Fasteners

Combination 87:
Fastener: EJOT DABO® TKR - 4 - 4,8 x L_s
Washer: EJOT® FP with EJOT® HTK-S - 20 x L_s

Annex 45

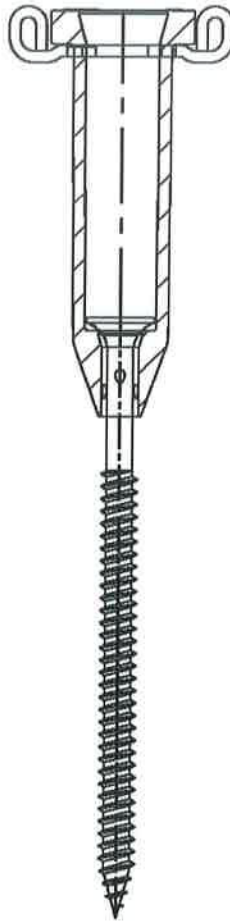

EJOT Dabo® VHT-R - 4,8 x L_s
EJOT Dabo® VHT-E - 4,8 x L_s

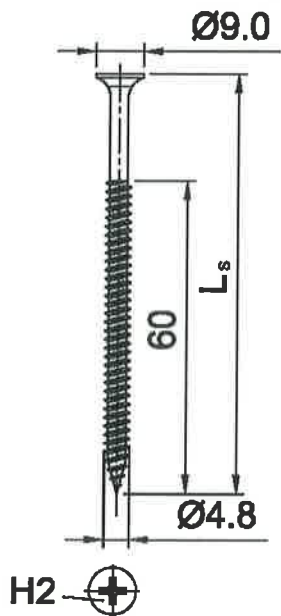

EJOT® FP, d = 14,5mm

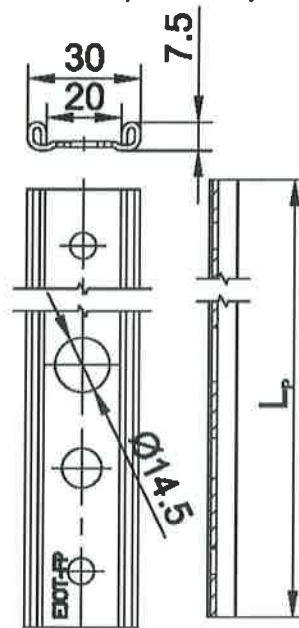

EJOT® HTK-S - 20 x L_B

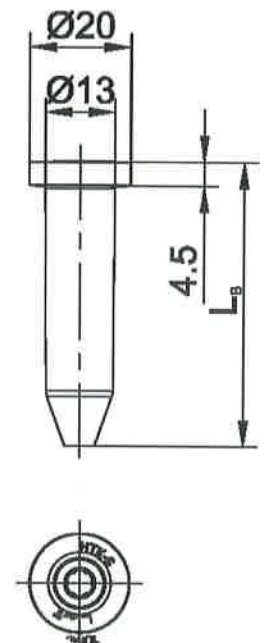

EJOT Flat Roof Fasteners

Combination 88-89:
Fastener: EJOT DABO® VHT-R - 4,8 x L_s / EJOT DABO® VHT-E - 4,8 x L_s
Washer: EJOT® FP with EJOT® HTK-S - 20 x L_B

Annex 46



Bauder Befestigungsschiene
6/10, d = 6,5mm

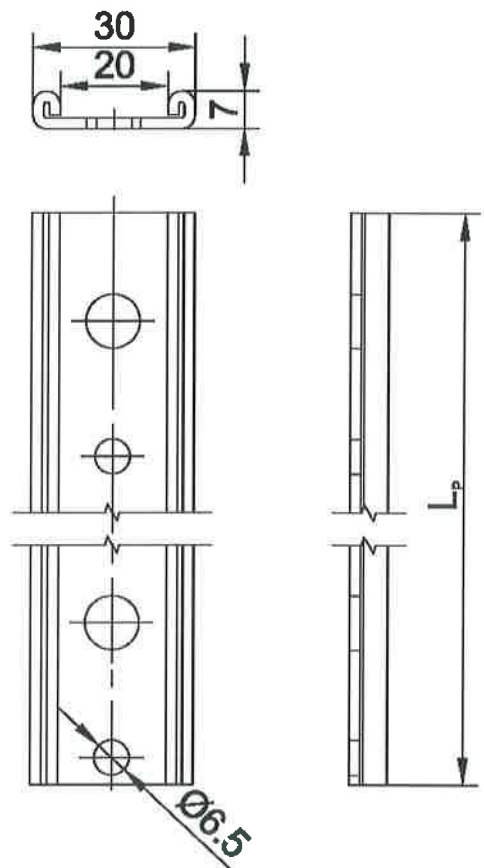
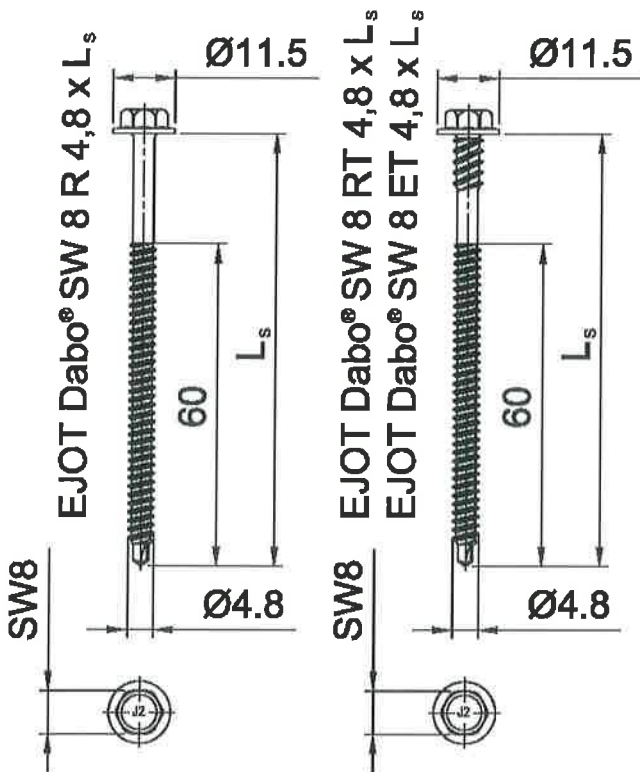

EJOT Flat Roof Fasteners

Combination 90-92:

Fastener: EJOT DABO® SW 8 R x L_s / DABO® SW 8 RT x L_s / DABO® SW 8 ET x L_s

Washer: Bauder Fastening Rail 6/10 Ø 6,5 mm

Annex 47

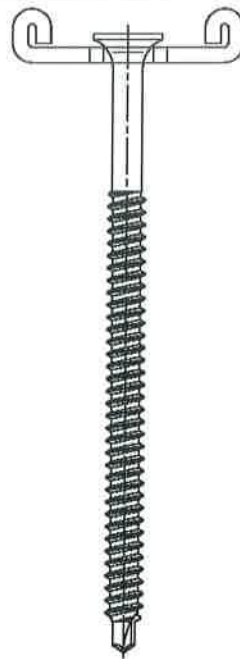

EJOT Dabo® TKR - 4,8 x L_s
EJOT Dabo® TKE - 4,8 x L_s

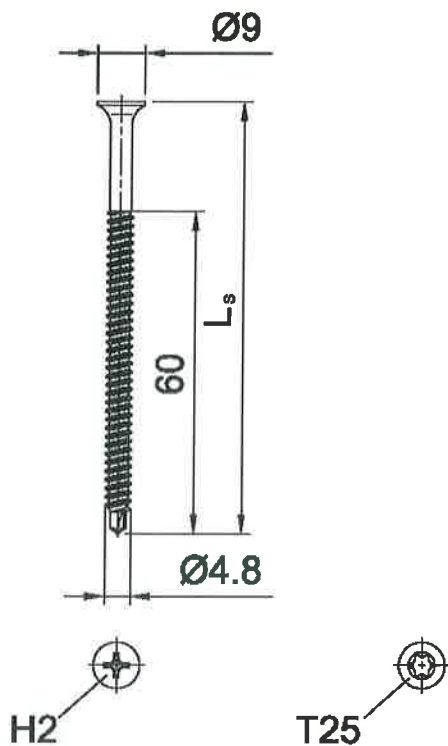

Bauder Befestigungsschiene
6/10, d = 6,5 mm

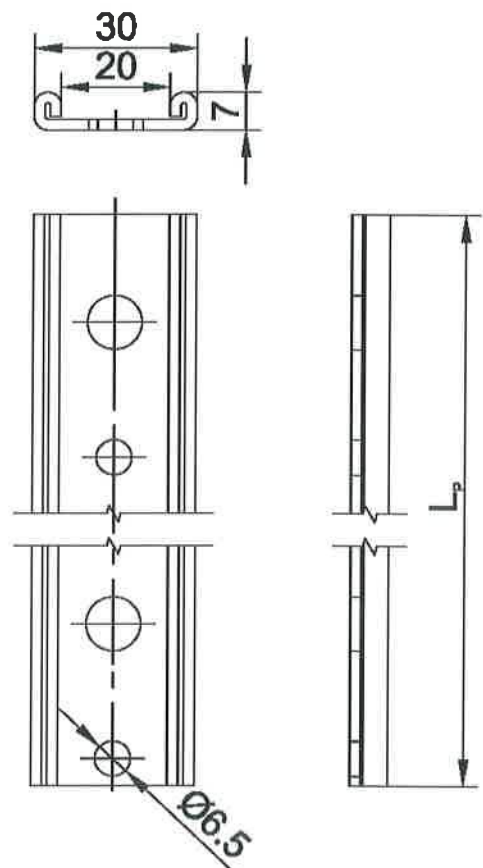

EJOT Flat Roof Fasteners

Combination 93-94:
Fastener: EJOT DABO® TKR – 4,8 x L_s / EJOT DABO® TKE – 4,8 x L_s
Washer: Bauder Fastening Rail 6/10 Ø 6,5 mm

Annex 48

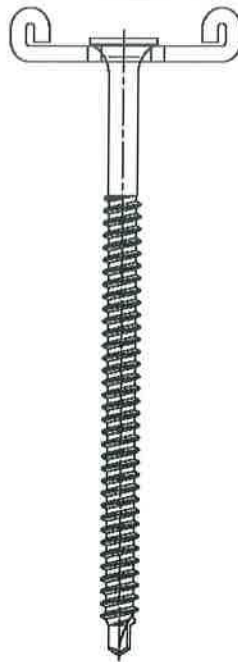

EJOT Dabo® TKR - 4 - 4,8 x L_s

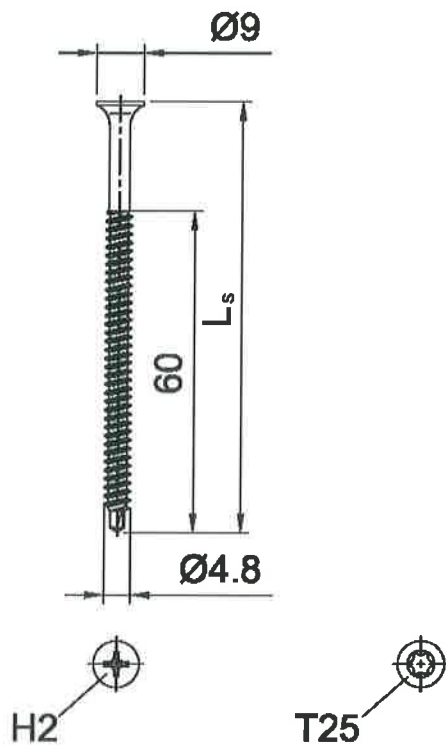

Bauder Befestigungsschiene
6/10, d = 6,5mm

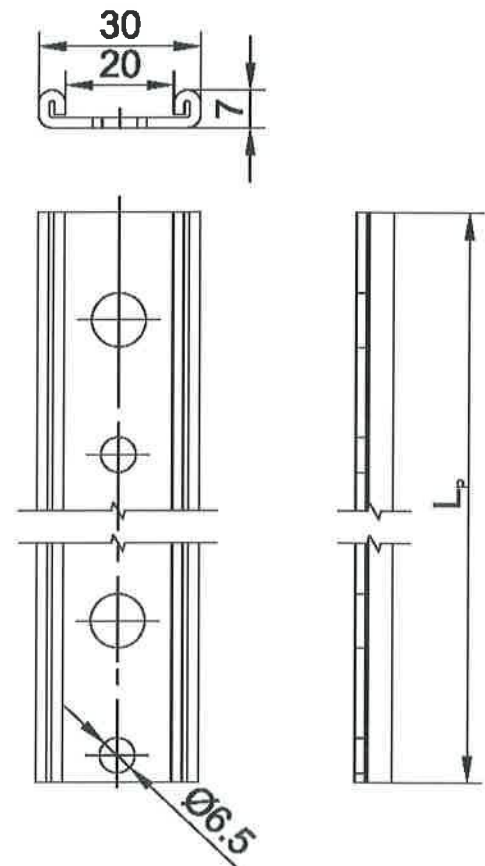

EJOT Flat Roof Fasteners

Combination 95:
Fastener: EJOT DABO® TKR - 4 - 4,8 x L_s
Washer: Bauder Fastening Rail 6/10 Ø 6,5 mm

Annex 49

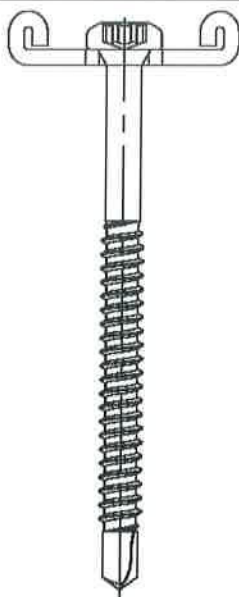

EJOT Dabo® TKR - ZT6 - 5,5 x L_s

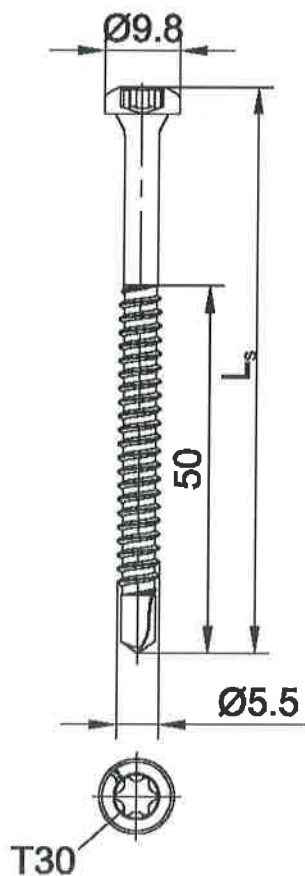

Bauder Befestigungsschiene
6/10, d = 6,5mm

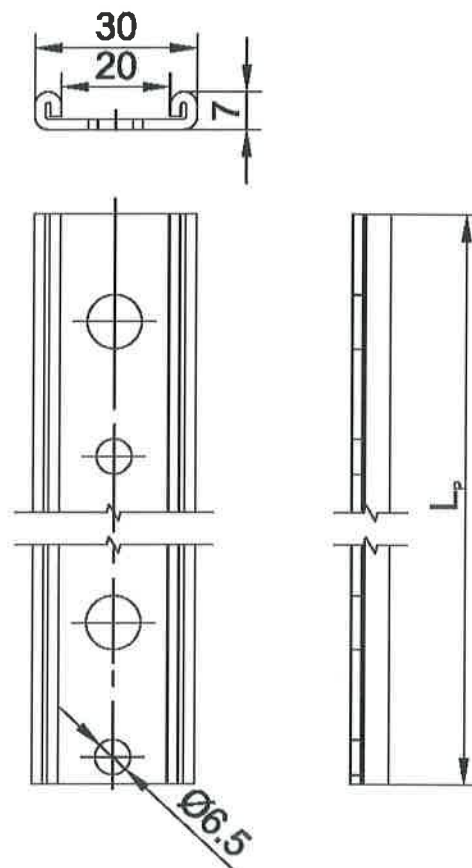

EJOT Flat Roof Fasteners

Combination 96:
Fastener: EJOT DABO® TKR – ZT6 – 5,5 x L_s
Washer: Bauder Fastening Rail 6/10 Ø 6,5 mm

Annex 50

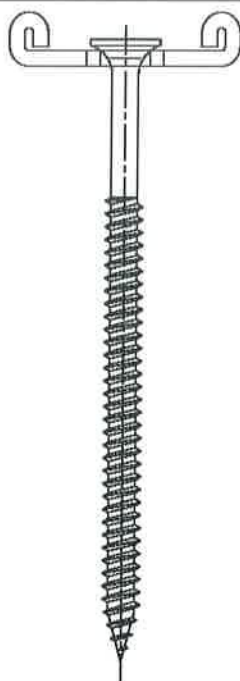

EJOT Dabo® VHT-R - 4,8 x L_s
EJOT Dabo® VHT-E - 4,8 x L_s

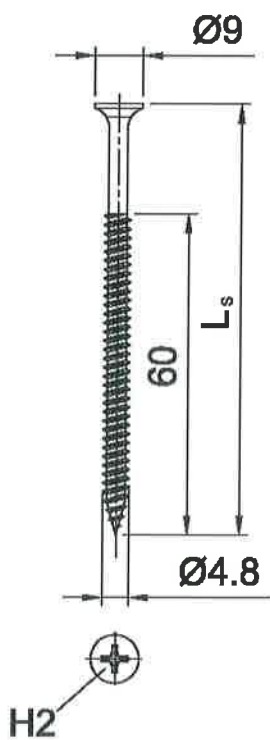

Bauder Befestigungsschiene
6/10, d = 6,5mm

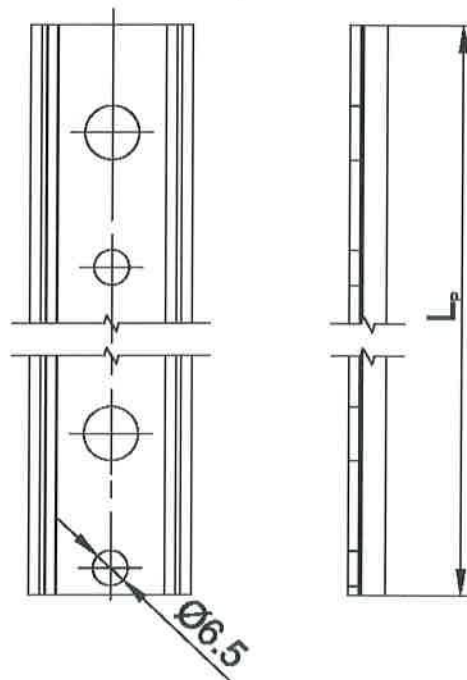
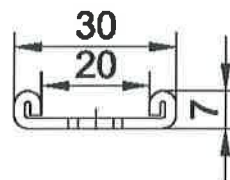

EJOT Flat Roof Fasteners

Combination 97-98:
Fastener: EJOT DABO® VHT-R - 4,8 x L_s / EJOT DABO® VHT-E - 4,8 x L_s
Washer: Bauder Fastening Rail 6/10 Ø 6,5 mm

Annex 51

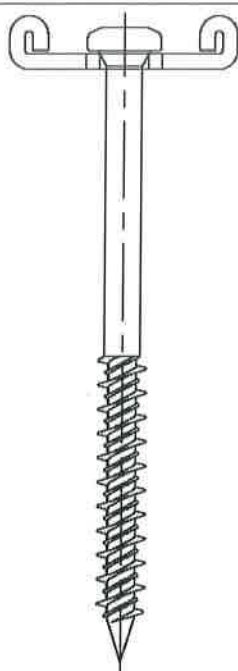

**Bauder Befestigungsschiene
6/10, d = 6,5mm**

EJOT® FBS - R - 6,3 x L_s

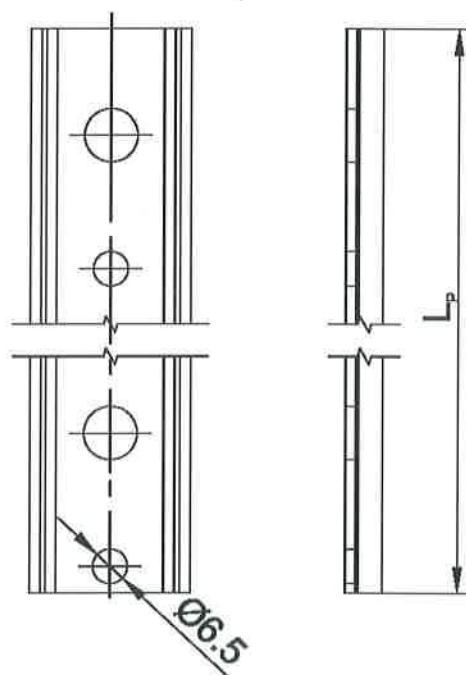
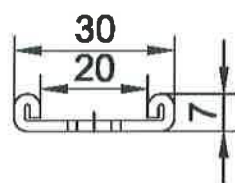
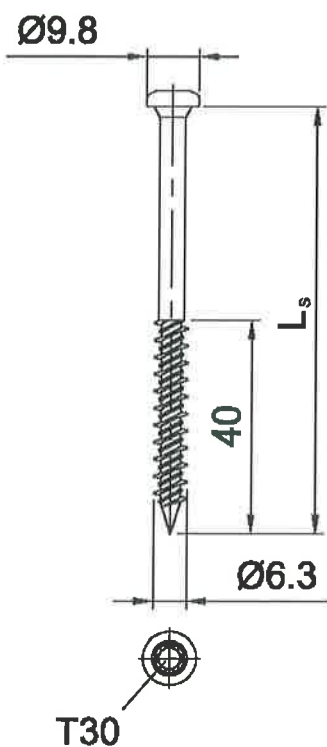

EJOT Flat Roof Fasteners

Combination 99:
Fastener: EJOT® FBS – R – 6,3 x L_s
Washer: Bauder Fastening Rail 6/10 Ø 6,5 mm

Annex 52

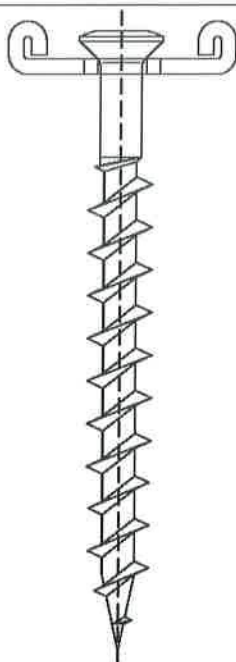

EJOT® FPS - E - 8,0 x L_s

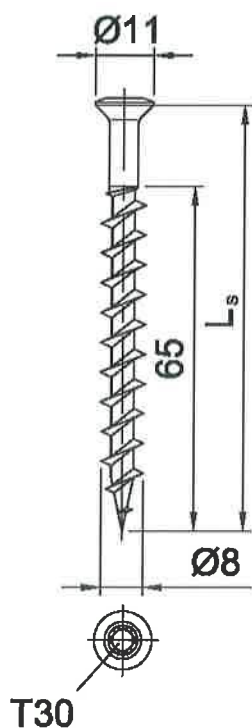

Bauder Befestigungsschiene
6/10, d = 6,5mm

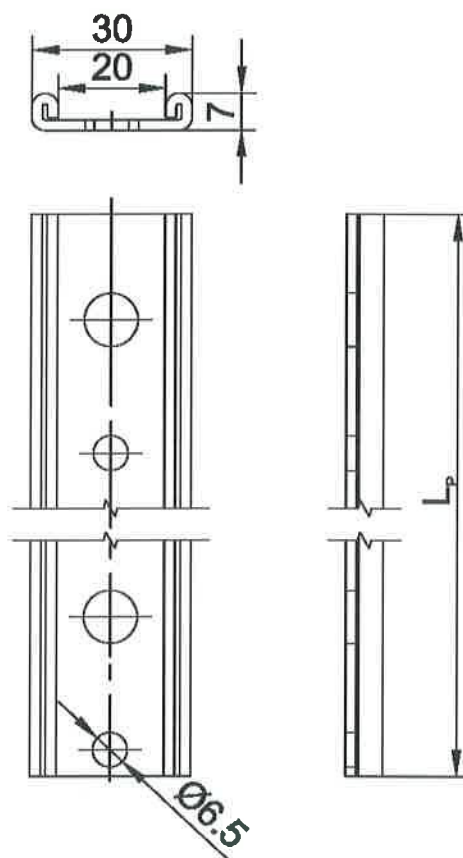

EJOT Flat Roof Fasteners

Combination 100:
Fastener: EJOT® FPS – E – 8,0 x L_s
Washer: Bauder Fastening Rail 6/10 Ø 6,5 mm

Annex 53

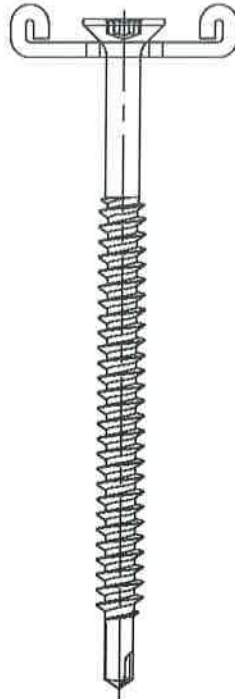

EJOT® JT2 - ST - 2 - 6,0 x L_s
EJOT® JT3 - ST - 2 - 6,0 x L_s

Bauder Befestigungsschiene
6/10, d = 6,5 mm

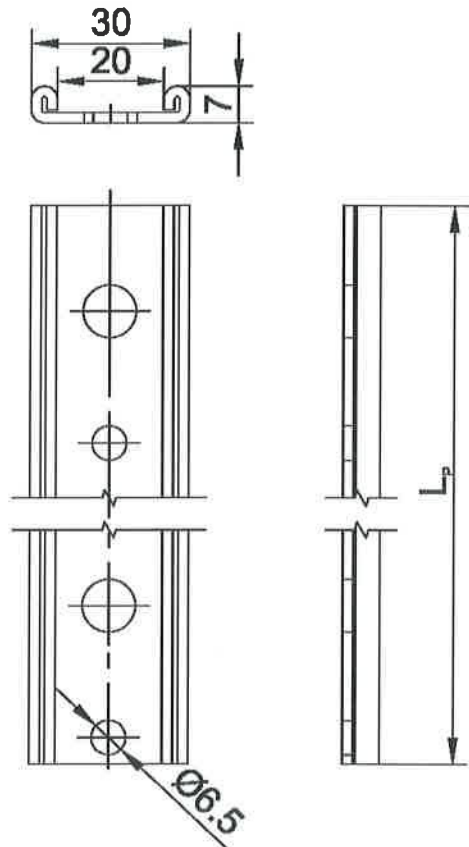
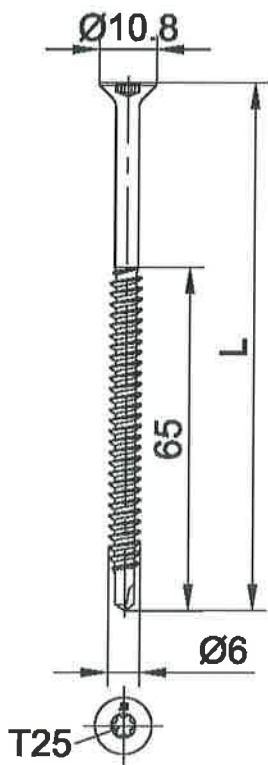

EJOT Flat Roof Fasteners

Combination 101-102:
Fastener: EJOT® JT2 - ST - 2 - 6,0 x L_s / EJOT® JT3 - ST - 2 - 6,0 x L_s
Washer: Bauder Fastening Rail 6/10 Ø 6,5 mm

Annex 54



EJOT®JT2 - ST - 2 - 6,8 x L_s

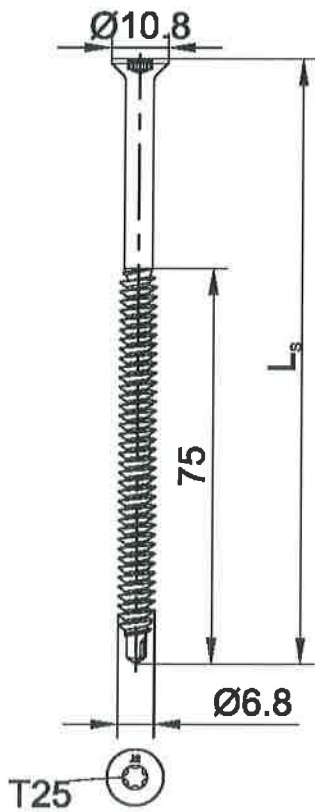

Bauder Befestigungsschiene
 6/10, d = 6,5mm

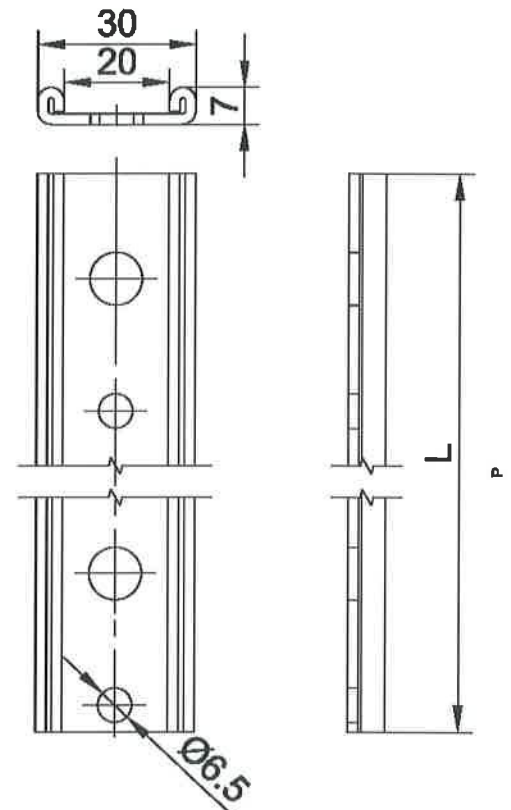

EJOT Flat Roof Fasteners

Combination 103:
 Fastener: EJOT® JT2 – ST – 2 – 6,8 x L_s
 Washer: Bauder Fastening Rail 6/10 Ø 6,5 mm

Annex 55

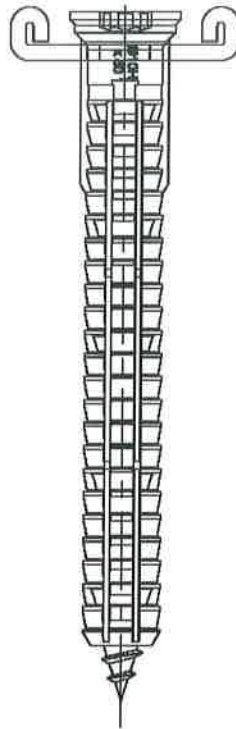

EJOT® SDF-S 10H x L - E

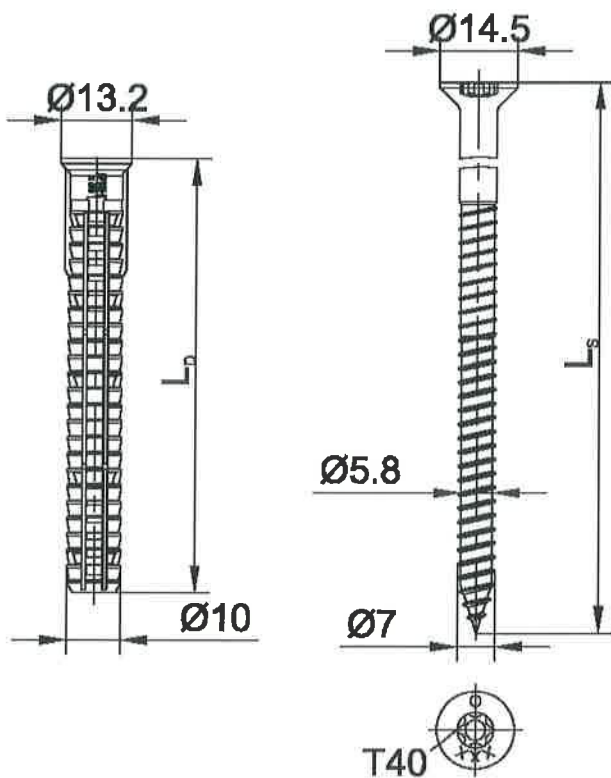

**Bauder Befestigungsschiene
6/10, d = 10mm**

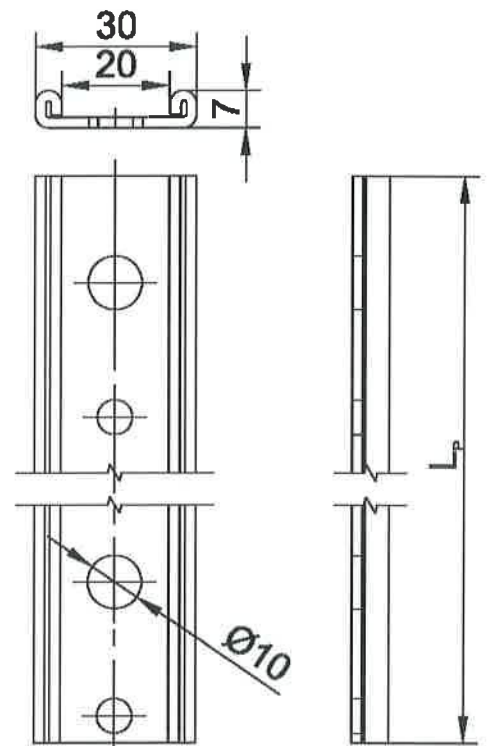

EJOT Flat Roof Fasteners

Combination 104:
Fastener: EJOT® SDF-S 10H x L - E
Washer: Bauder Fastening Rail 6/10 Ø 10mm

Annex 56

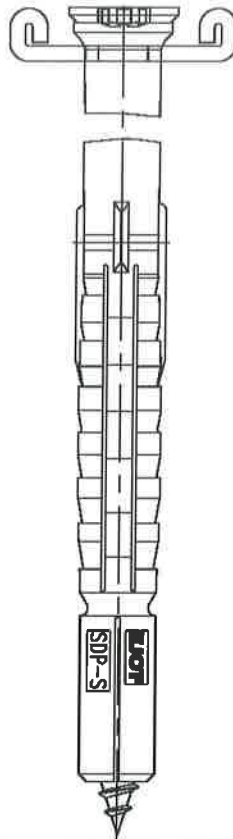

EJOT® SDP-S 10G x L - E

Bauder Befestigungsschiene
6/10, d = 10mm

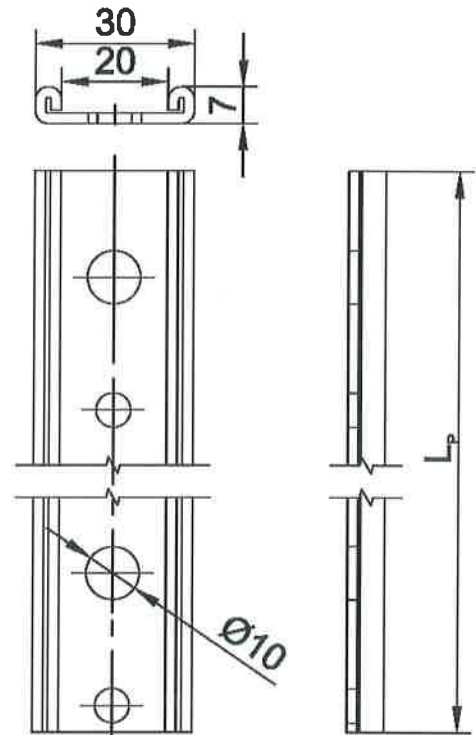
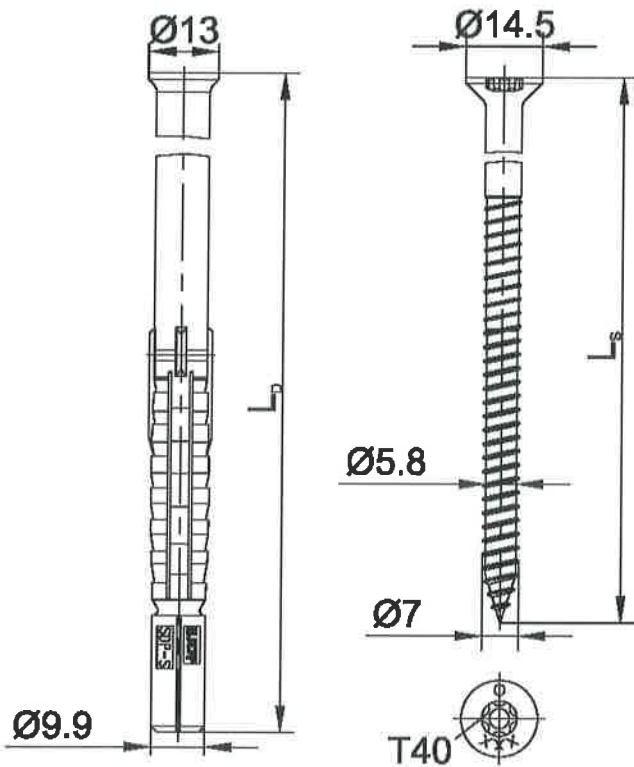

EJOT Flat Roof Fasteners

Combination 105:
Fastener: EJOT® SDP-S 10G x L - E
Washer: Bauder Fastening Rail 6/10 Ø 10mm

Annex 57

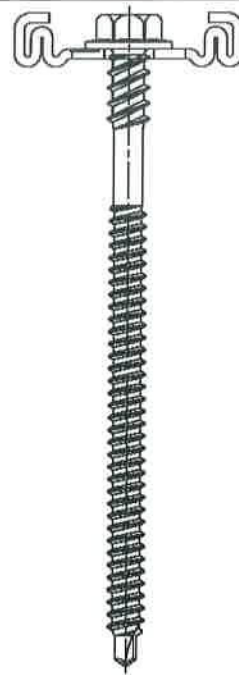
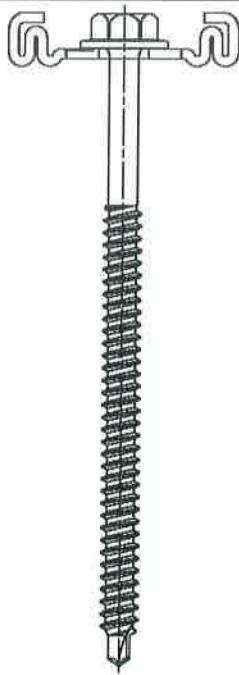

Sika Sarnabar® S6, d = 6,5mm
Sika Sarnabar® S6/10, d = 6,5mm
Sika Sarnabar® S6/15, d = 6,5mm

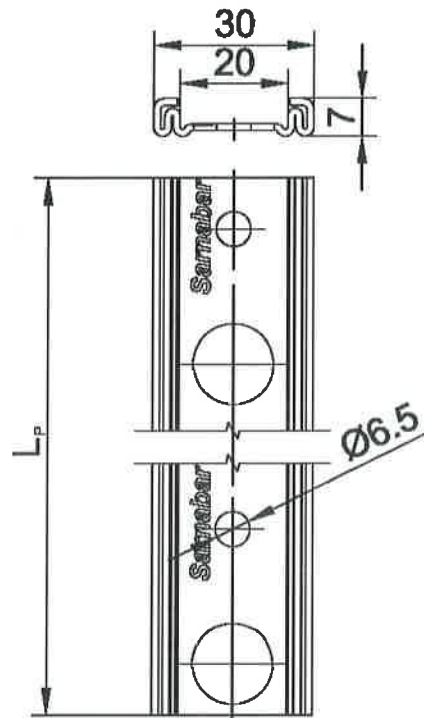
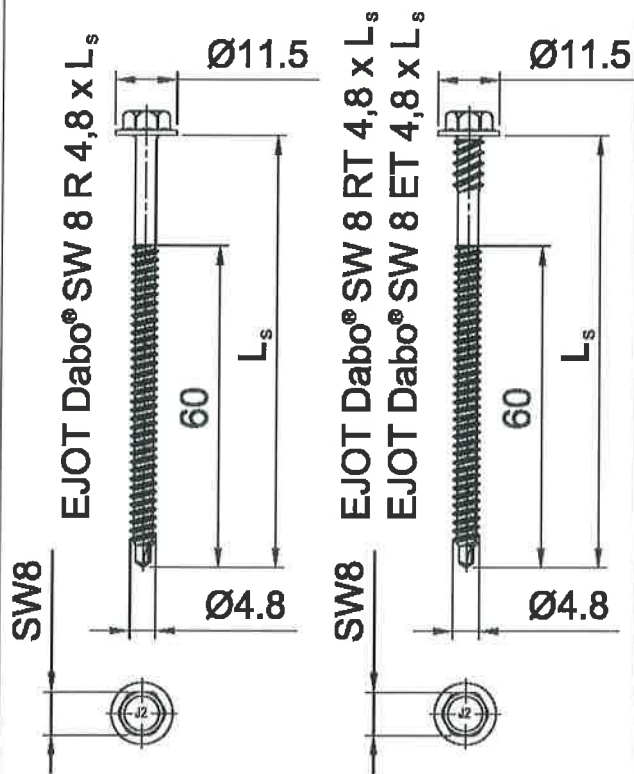

EJOT Flat Roof Fasteners

Combination 106-114:
Fastener: EJOT DABO® SW 8 R x L_s / DABO® SW 8 RT x L_s / DABO® SW 8 ET x L_s
Washer: SIKASarnabar® S 6 / Sarnabar® S 6/10 / Sarnabar® S 6/15 Ø 6,5mm

Annex 58

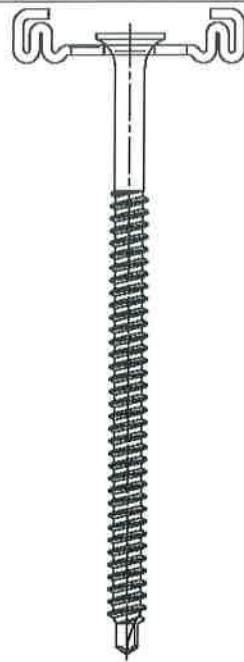

EJOT Dabo® TKR - 4,8 x L_s
EJOT Dabo® TKE - 4,8 x L_s

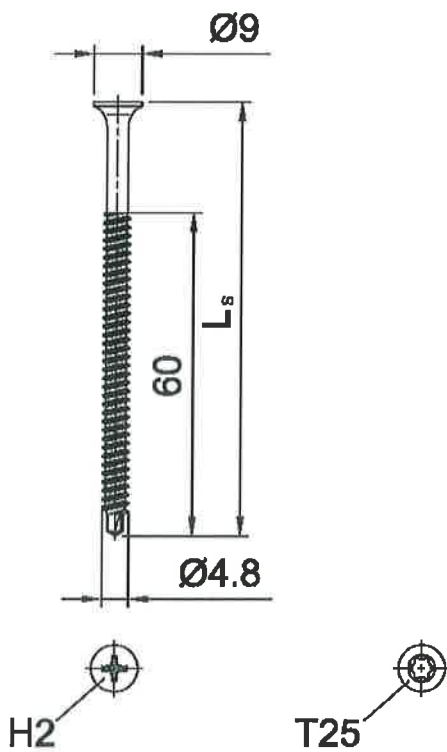

Sika Sarnabar® S6, d = 6,5mm
Sika Sarnabar® S6/10, d = 6,5mm
Sika Sarnabar® S6/15, d = 6,5mm

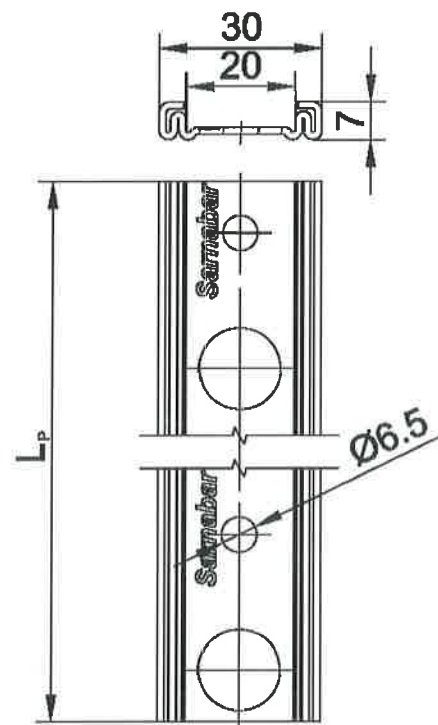

EJOT Flat Roof Fasteners

Combination 115-120:
Fastener: EJOT DABO® TKR - 4,8 x L_s / EJOT DABO® TKE - 4,8 x L_s
Washer: SIK A Sarnabar® S 6 / Sarnabar® S 6/10 / Sarnabar® S 6/15 Ø 6,5mm

Annex 59

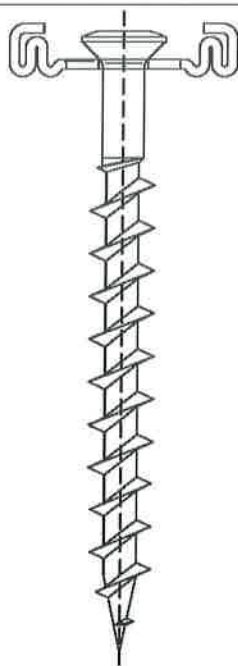

EJOT® FPS - E - 8,0 x L_s

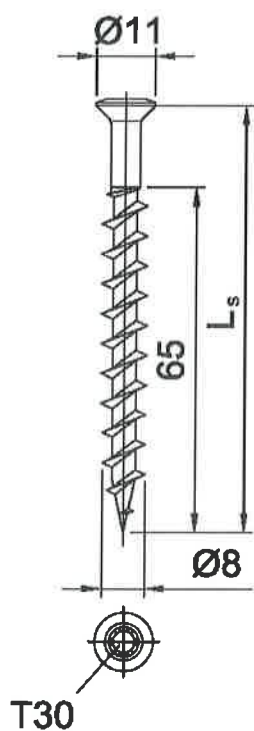

Sika Sarnabar® S6, d = 6,5mm
Sika Sarnabar® S6/10, d = 6,5mm
Sika Sarnabar® S6/15, d = 6,5mm

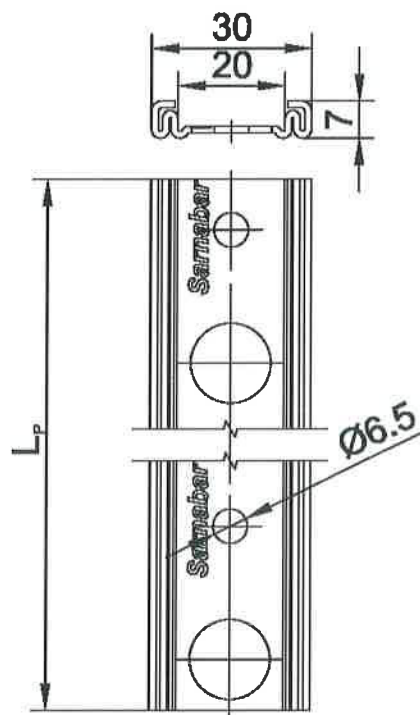

EJOT Flat Roof Fasteners

Combination 121-123:
Fastener: EJOT® FPS - E - 8,0 x L_s
Washer: SIKA Sarnabar® S 6 / Sarnabar® S 6/10 / Sarnabar® S 6/15 Ø 6,5m

Annex 60

Characteristic Values of Axial Load Resistance [kN]

An. No.	Combination Screw / Washer or Screw / Railsystem	Steel S280GD - EN 10346 or S235 - EN 10025 with $R_m \geq 360 \text{ N/mm}^2$			Aluminium - EN 485 with $R_m \geq 195 \text{ N/mm}^2$			Timber					
		$t = 0,50 \text{ mm}$	$t = 0,63 \text{ mm}$	$t = 0,75 \text{ mm}$	$t = 1,50 \text{ mm}$	$t = 3,0 \text{ mm}$	$t = 0,80 \text{ mm}$	$t = 1,00 \text{ mm}$	$t \geq 1,20 \text{ mm}$	Structural Timber EN 338/C24 $t \geq 24 \text{ mm}$	Chipboard P4 EN 12369-1 $t \geq 19 \text{ mm}$	Plywood EN 12369-2 $t \geq 21 \text{ mm}$	OSB/3 EN 12369-1 $t \geq 18 \text{ mm}$
1	Dabo® SW 8 R - 4,8 x L Dabo® SW 8 RT - 4,8 x L Dabo® SW 8 ET - 4,8 x L	—	—	1.06	—	—	—	—	1.62	—	—	1.87	1.12
2	Dabo® TKR - 4,8 x L Dabo® TKE - 4,8 x L	—	—	1.06	—	—	—	—	1.62	—	—	1.87	1.12
3	Dabo® TKR - 4 - 4,8 x L Dabo® VHT-R - 4,8 x L	—	—	1.06	1.20	1.20	—	—	1.20	—	—	1.20	1.12
4	Dabo® VHT-E - 4,8 x L Dabo® TKR - 4,8 x L	0.67	0.86	1.06	—	—	—	—	0.90	1.21	1.30	1.30	1.30
5	Dabo® TKR - 4,8 x L Dabo® TKE - 4,8 x L	—	—	1.06	—	—	—	—	1.62	—	—	1.87	1.12
6	Dabo® TKR - 4 - 4,8 x L Dabo® VHT-R - 4,8 x L	—	—	—	2.08	2.08	—	—	1.62	—	—	1.87	1.12
7	Dabo® VHT-E - 4,8 x L Dabo® SW 8 R - 4,8 x L	0.67	0.86	1.06	—	—	—	—	0.90	1.21	2.61	1.76	1.76
8	Dabo® SW 8 RT - 4,8 x L Dabo® TKR - 4,8 x L	0.67	0.86	1.06	—	—	—	0.70	0.93	1.16	2.61	1.76	1.76
9	Dabo® TKR - 4,8 x L Dabo® TKE - 4,8 x L	—	—	1.06	—	—	—	—	1.62	—	—	1.78	1.12
10	Dabo® TKR - 4 - 4,8 x L Dabo® TKR - ZT6 - 5,5 x L	—	—	—	1.78	1.78	—	—	1.62	—	—	1.78	1.12
11	Dabo® VHT-R - 4,8 x L Dabo® VHT-E - 4,8 x L	0.67	0.86	1.06	—	—	—	—	0.90	1.21	—	1.78	1.76
12	Dabo® VHT-E - 4,8 x L Dabo® TKR - 4,8 x L	0.67	0.86	1.06	—	—	—	0.70	0.93	1.16	1.21	1.73	1.76
13	Dabo® TKE - 4,8 x L Dabo® TKR - 4 - 4,8 x L	—	—	1.06	—	—	—	—	1.62	—	—	1.73	1.12
14	Dabo® TKR - 4 - 4,8 x L Dabo® TKR - ZT6 - 5,5 x L	—	—	—	1.73	1.73	—	—	1.62	—	—	1.73	1.12
15	Dabo® VHT-R - 4,8 x L Dabo® VHT-E - 4,8 x L	0.67	0.86	1.06	—	—	—	—	0.90	1.21	—	—	—
16	Dabo® VHT-E - 4,8 x L Dabo® TKR - 4,8 x L	0.67	0.86	1.06	—	—	—	0.70	0.93	1.16	1.21	1.73	1.73
17	Dabo® TKR - 4,8 x L Dabo® TKE - 4,8 x L	—	—	1.06	—	—	—	—	1.58	—	—	1.58	1.12
18	Dabo® TKR - 4 - 4,8 x L Dabo® TKR - ZT6 - 5,5 x L	—	—	—	1.58	1.58	—	—	1.58	—	—	1.58	1.12
19	Dabo® VHT-R - 4,8 x L Dabo® VHT-E - 4,8 x L	0.67	0.86	1.06	—	—	—	—	0.90	1.21	—	—	—
20	Dabo® VHT-E - 4,8 x L JT2 - ST - 2 - 6,0 x L	0.67	0.86	1.06	—	—	—	0.70	0.93	1.16	1.21	1.58	1.58
21	JT3 - ST - 2 - 6,0 x L	0.69	0.87	1.08	1.58	1.58	—	—	1.57	—	—	—	1.32
22	HTVRU 40/L-W	0.69	0.87	1.08	1.58	1.58	—	0.52	0.70	0.95	1.15	1.15	1.32

EJOT Flat Roof Fasteners

Characteristic Values of Axial Load Resistance

Annex 61

English translation prepared by DIBt

Characteristic Values of Axial Load Resistance [kN]												
An. - No.	Combination Screw/Washer or Screw/Railsystem	Steel S280GD - EN 10346 or S235 - EN 10025 with $R_m \geq 360 \text{ N/mm}^2$			Aluminum - EN 485 with $R_m \geq 195 \text{ N/mm}^2$			Timber		OSB/3 EN 12369-1 $t \geq 18\text{mm}$		
		$t = 0,50\text{mm}$	$t = 0,63\text{mm}$	$t = 0,75\text{mm}$	$t = 1,50\text{mm}$	$t = 3,0\text{mm}$	$t = 0,80\text{mm}$	$t = 1,00\text{mm}$	Structural Timber EN 338/C24 $t \geq 24\text{mm}$		Chipboard P4 EN 12369-1 $t \geq 19\text{mm}$	Plywood EN 12369-2 $t \geq 21\text{mm}$
33	Dabo® SW 8 R 4,8 x L	—	—	1,06	—	—	—	—	1,62	—	1,87	1,12
	Dabo® SW 8 RT 4,8 x L	—	—	1,06	—	—	—	—	1,62	—	1,87	1,12
	Dabo® SW 8 ET 4,8 x L	—	—	1,06	—	—	—	—	1,62	—	1,87	1,12
34	Dabo® TKR - 4,8 x L	—	—	1,06	—	—	—	—	1,62	—	1,87	1,12
	Dabo® TKE - 4,8 x L	—	—	1,06	—	—	—	—	1,62	—	1,87	1,12
35	Dabo® TKR - 4 - 4,8 x L	—	—	—	2,08	2,08	—	—	—	—	—	—
36	Dabo® TKR - ZT6 - 5,5 x L	—	—	—	—	3,65	—	—	—	—	—	—
37	Dabo® VHT-R - 4,8 x L	0,67	0,86	1,06	—	—	—	—	0,90	1,21	2,61	1,76
	Dabo® VHT-E - 4,8 x L	0,67	0,86	1,06	—	—	0,70	0,93	0,90	1,21	2,61	1,76
40	JT2 - ST - 2 - 6,0 x L	0,69	0,87	1,08	3,43	—	—	—	1,57	—	—	1,32
	JT3 - ST - 2 - 6,0 x L	0,69	0,87	1,08	3,43	—	0,52	0,70	1,57	—	—	1,32
41	JT2 - ST - 2 - 6,8 x L	0,97	1,31	1,65	3,65	—	—	—	—	—	—	—
44	Dabo® TKR - 4,8 x L	—	—	1,06	—	—	—	—	1,62	—	1,87	1,12
	Dabo® TKE - 4,8 x L	—	—	1,06	—	—	—	—	1,62	—	1,87	1,12
45	Dabo® TKR - 4 - 4,8 x L	—	—	—	2,08	2,08	—	—	—	—	—	—
	Dabo® VHT-R - 4,8 x L	0,67	0,86	1,06	—	—	—	—	0,90	1,21	2,25	1,76
46	Dabo® VHT-E - 4,8 x L	0,67	0,86	1,06	—	—	0,70	0,93	0,90	1,21	2,25	1,76
47	Dabo® SW 8 R 4,8 x L	—	—	1,06	—	—	—	—	1,62	—	1,87	1,12
	Dabo® SW 8 RT 4,8 x L	—	—	1,06	—	—	—	—	1,62	—	1,87	1,12
	Dabo® SW 8 ET 4,8 x L	—	—	1,06	—	—	—	—	1,62	—	1,87	1,12
48	Dabo® TKR - 4,8 x L	—	—	1,06	—	—	—	—	1,62	—	1,87	1,12
	Dabo® TKE - 4,8 x L	—	—	1,06	—	—	—	—	1,62	—	1,87	1,12
49	Dabo® TKR - 4 - 4,8 x L	—	—	—	2,08	2,08	—	—	—	—	—	—
50	Dabo® TKR - ZT6 - 5,5 x L	—	—	—	—	3,65	—	—	—	—	—	—
51	Dabo® VHT-R - 4,8 x L	0,67	0,86	1,06	—	—	—	—	0,90	1,21	2,61	1,76
	Dabo® VHT-E - 4,8 x L	0,67	0,86	1,06	—	—	0,70	0,93	0,90	1,21	2,61	1,76
54	JT2 - ST - 2 - 6,0 x L	0,69	0,87	1,08	3,43	—	—	—	1,57	—	—	1,32
	JT3 - ST - 2 - 6,0 x L	0,69	0,87	1,08	3,43	—	0,52	0,70	1,57	—	—	1,32
55	JT2 - ST - 2 - 6,8 x L	0,97	1,31	1,65	3,65	—	—	—	—	—	—	—
58	Dabo® SW 8 R 4,8 x L	—	—	1,06	—	—	—	—	1,62	—	1,87	1,12
	Dabo® SW 8 RT 4,8 x L	—	—	1,06	—	—	—	—	1,62	—	1,87	1,12
	Dabo® SW 8 ET 4,8 x L	—	—	1,06	—	—	—	—	1,62	—	1,87	1,12
59	Dabo® TKR - 4,8 x L	—	—	1,06	—	—	—	—	1,62	—	1,87	1,12
	Dabo® TKE - 4,8 x L	—	—	1,06	—	—	—	—	1,62	—	1,87	1,12

EJOT Flat Roof Fasteners

Characteristic Values of Axial Load Resistance

Annex 62

Characteristic Values of Axial Load Resistance [kN]						
An.- No.	Combination Screw / Washer or Screw / Railsystem	Concrete				
		Concrete C12/15 EN 206-1 $h_{ef} \geq 30\text{mm}$	Lightweight LC12/13 EN 206-1 $h_{ef} \geq 30\text{mm}$	Concrete $h_{ef} \geq 60\text{mm}$	Aerated Concrete P3,3/0,5 EN 12602 $h_{ef} \geq 65\text{mm}$	$h_{ef} \geq 70\text{mm}$
23	FBS - R - 6,3 x L	1.78	—	—	—	—
24	FPS - E - 8,0 x L	—	—	—	—	—
25	FBS - R - 6,3 x L	1.73	—	1.72	—	—
26	FPS - E - 8,0 x L	—	—	—	—	—
27	FBS - R - 6,3 x L	1.58	—	1.72	—	—
28	FPS - E - 8,0 x L	—	—	—	—	—
29	JBS - R - 7,5 x L	1.58	—	1.58	—	—
30	FDDplus 50 x L - R / FDDplus 50 x L - E (one-part)	1.35	1.34	—	1.78	—
31	FDDplus 50 x L - R / FDDplus 50 x L - E (two-parts)	1.35	1.34	—	1.78	—
32	FDDplus "S" 50 x L - R / FDDplus "S" 50 x L - E	1.35	1.34	—	1.78	—
38	FBS - R - 6,3 x L	2.88	—	—	—	—
39	FPS - E - 8,0 x L	—	—	—	—	—
42	SDF-S 10H x L - E	4.00	—	1.72	—	—
43	SDP-S 10G x L - E	—	—	—	—	1.31
52	FBS - R - 6,3 x L	2.88	—	—	—	—
53	FPS - E - 8,0 x L	—	—	—	—	—
56	SDF-S 10H x L - E	4.00	—	1.72	—	—
57	SDP-S 10G x L - E	—	—	—	—	1.31
60	FPS - E - 8,0 x L	—	—	1.72	—	—

EJOT Flat Roof Fasteners

Characteristic Values of Axial Load Resistance

Annex 63